

8 7 6 5 4 3 2 1

NOTES:
1. PURCHASE McMASTER P/N 8239K27; USE THIS CAP.

REVISIONS				
ZONE	REV.	DESCRIPTION	DATE	APPROVED

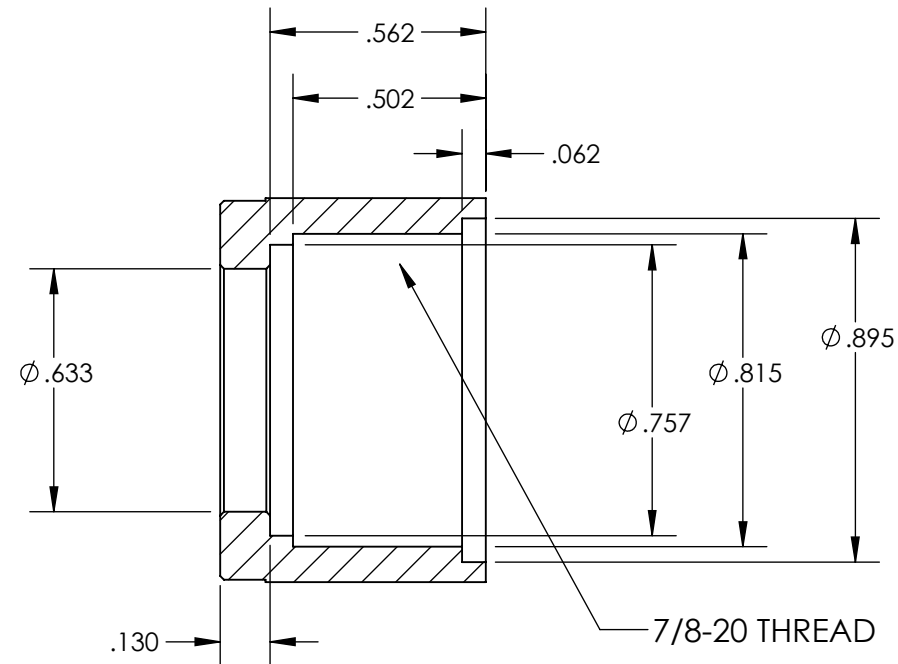
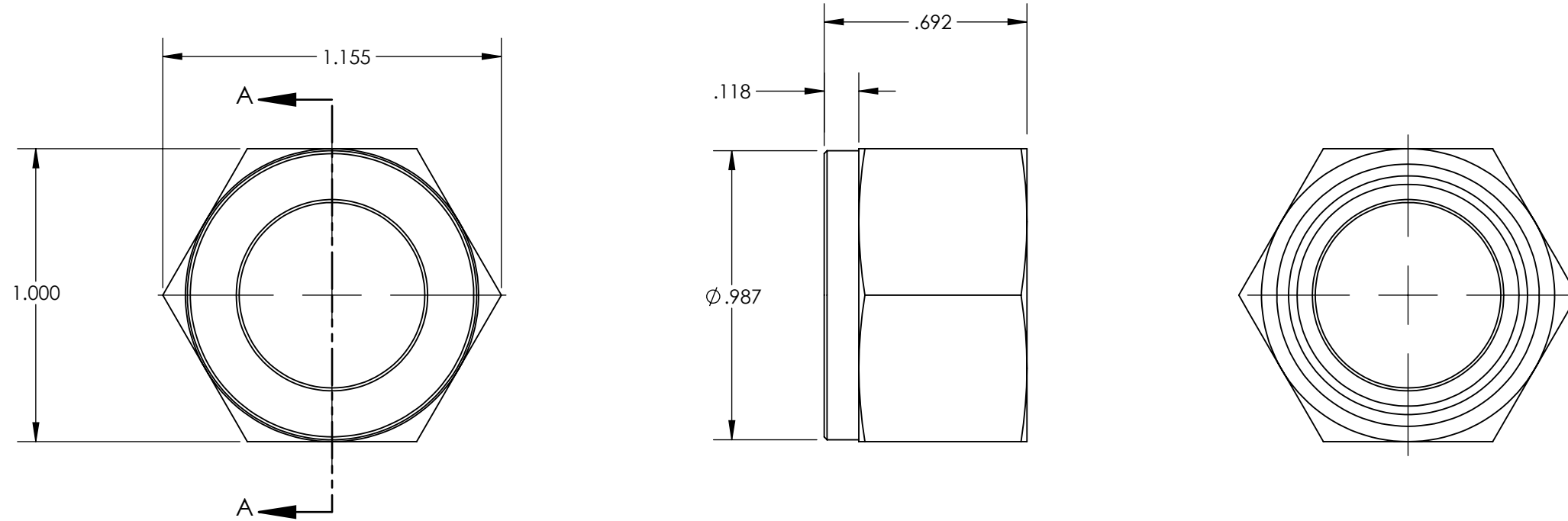

SECTION A-A

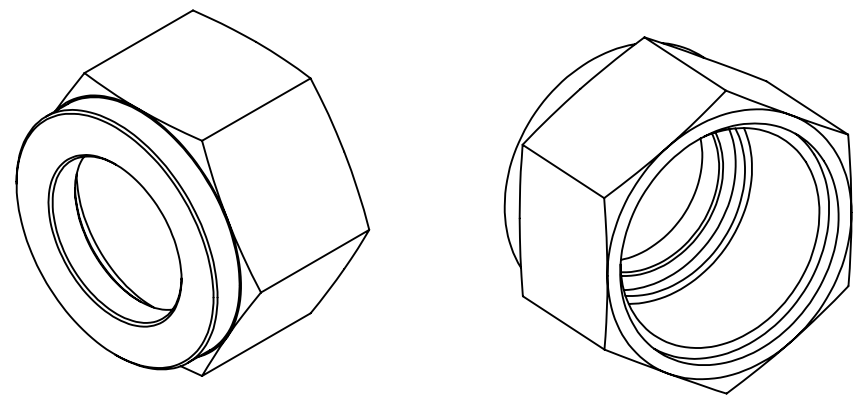

PROPRIETARY AND CONFIDENTIAL
THE INFORMATION CONTAINED IN THIS DRAWING IS THE SOLE PROPERTY OF EMPIRE MAGNETICS, INC. ANY REPRODUCTION IN PART OR AS A WHOLE WITHOUT THE WRITTEN PERMISSION OF EMPIRE MAGNETICS, INC. IS PROHIBITED.

UNLESS OTHERWISE SPECIFIED:		NAME	DATE	EMPIRE MAGNETICS, INC. ROHNERT PARK, CA 94928	
DIMENSIONS ARE IN INCHES		DRAWN	DTI	9-14-11	TITLE: CAP FITTING
TOLERANCES:		CHECKED			
FRACTIONAL ±		ENG APPR.			
ANGULAR: ±0.5		MFG APPR.			
TWO PLACE DECIMAL ±.010		Q.A.			SIZE DWG. NO. REV B 10-0006-0072
THREE PLACE DECIMAL ±.005		COMMENTS:	CAP FITTING		
INTERPRET GEOMETRIC TOLERANCING PER:	MATERIAL				
	STAINLESS STEEL				
FINISH	N/A				
NEXT ASSY	USED ON				
APPLICATION	DO NOT SCALE DRAWING				

8 7 6 5 4 3 2 1

D
C
B
A

D
C
B
A