

8 7 6 5 4 3 2 1

| ZONE | | REV. | REVISIONS DESCRIPTION | DATE | APPROVED |
|------|--|------|-----------------------|------|----------|
| | | | | | |

NOTE:
1. PURCHASE MCMMASTER P/N 8239K27; USE THIS FERRULE.

PRELIMINARY 1

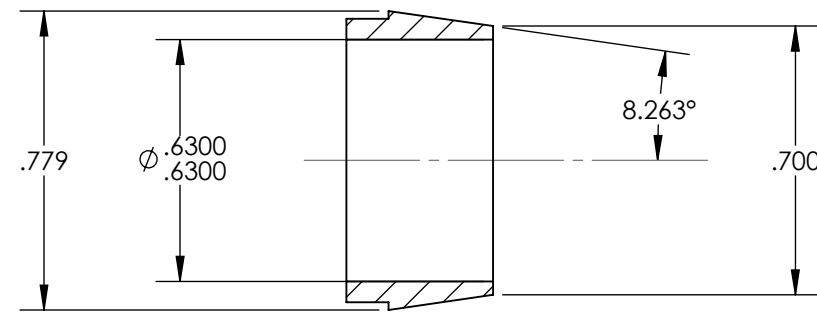
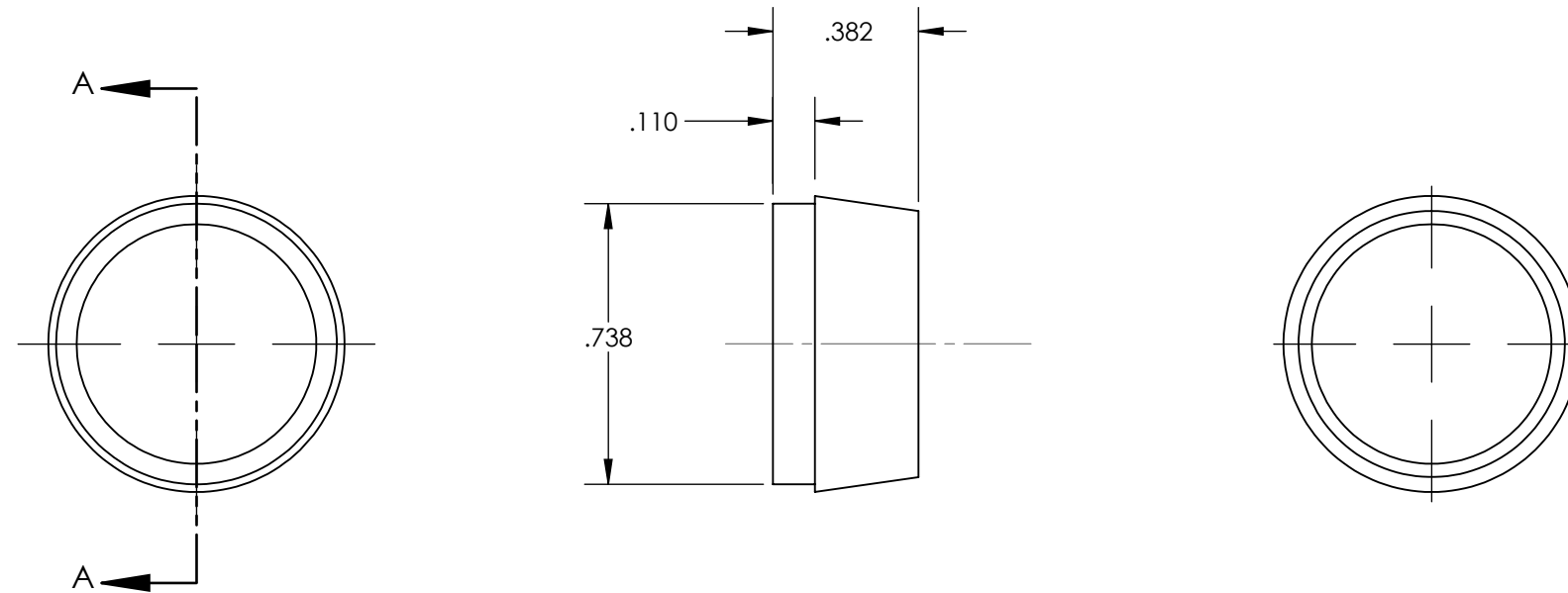

SECTION A-A

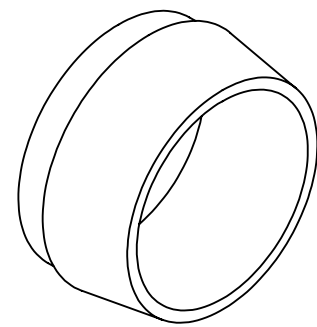

PROPRIETARY AND CONFIDENTIAL
THE INFORMATION CONTAINED IN THIS DRAWING IS THE SOLE PROPERTY OF EMPIRE MAGNETICS, INC. ANY REPRODUCTION IN PART OR AS A WHOLE WITHOUT THE WRITTEN PERMISSION OF EMPIRE MAGNETICS, INC. IS PROHIBITED.

| | | | | | |
|--------------------------------------|---------|----------------------|------|--|--|
| UNLESS OTHERWISE SPECIFIED: | | NAME | DATE | EMPIRE MAGNETICS, INC. ROHNERT PARK, CA 94928 | |
| DIMENSIONS ARE IN INCHES | | DRAWN | DTI | 9-14-11 | |
| TOLERANCES: | | CHECKED | | TITLE: | |
| FRACTIONAL \pm | | ENG APPR. | | FERRULE (FITTING) | |
| ANGULAR: ± 0.5 | | MFG APPR. | | SIZE | |
| TWO PLACE DECIMAL $\pm .010$ | | Q.A. | | DWG. NO. | |
| THREE PLACE DECIMAL $\pm .005$ | | COMMENTS: | | REV | |
| INTERPRET GEOMETRIC TOLERANCING PER: | | FERRULE 1 | | SCALE: 2:1 | |
| MATERIAL | | STAINLESS STEEL | | SHEET 1 OF 1 | |
| FINISH | | N/A | | | |
| NEXT ASSY | USED ON | | | | |
| APPLICATION | | DO NOT SCALE DRAWING | | | |

8 7 6 5 4 3 2 1