

# Design, Construction, Testing and Experiments with a new compact X/Z-pinch driver at IAC

Roman Shapovalov

Wendland Beezhold

Feb 20, 2013, IAC

# Outline

1. Introduction to X -Pinch / Z – Pinch  
(what and why)
2. Possible designs at IAC
  - 1<sup>st</sup> plan: ISIS ICD modification
  - 2<sup>nd</sup> plan: separate Marx + PFL
  - 3<sup>rd</sup> plan: new Compact PRS
  - 4<sup>th</sup> plan: new LTD cavity
3. Conclusion

# What is X - Pinch / Z - Pinch

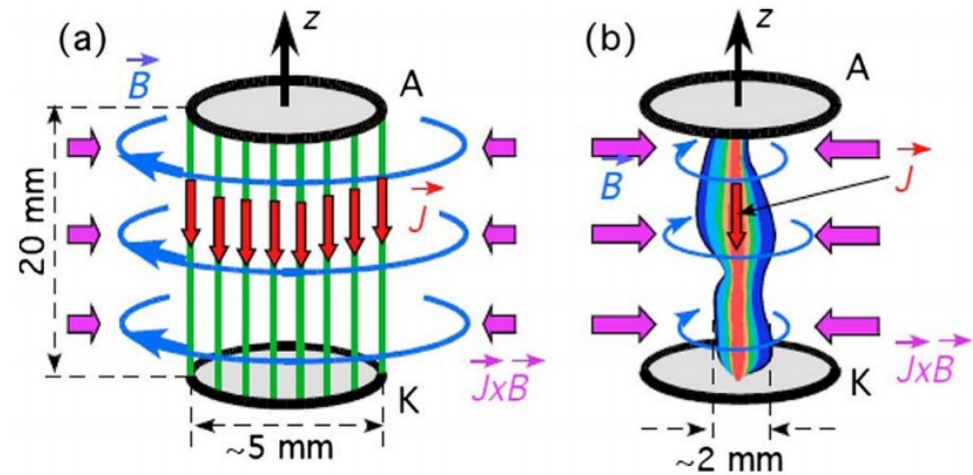
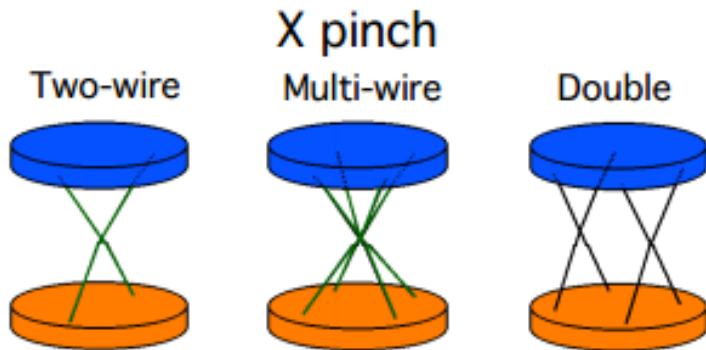

- \* two or more 5 – 100  $\mu\text{m}$  metal wires crossed at one point
- \* 100 – 300 kA, 1 kA/ns and more
- \* small (few  $\mu\text{m}$ ), bright (hundreds of mJ) and short (0.1-10ns) X-ray source

- \* cylindrical one or more metal wire array
- \* 1 MA and more current
- \* short duration, high power (hundreds of TW) radiation pulse

# Why is X- Pinch / Z – Pinch (Motivation)

## X – Pinch Application:

- \* intense, short pulse X-Ray source
- \* fast diagnostic tools for pulsed hot/warm plasma
- \* high spatial resolution imaging
- \* weapon effect testing to simulate X-Ray and Neutron radiation from WMD
- \* and more

## Z – Pinch Application

- \* Pulsed Fusion Energy (Z-Machine)
- \* Z - Pinch Dynamic – Hohlräume (DH) study
- \* wire initiation, ablation, implosion and stagnation research

## X – Pinch and Z – Pinch Application

- \* High Energy Density Physics (HEDP) Research
- \* Basic Plasma Physics Science (EOS, radiation mechanism, radiation transport, spectral properties, instabilities and more )

**1<sup>st</sup> possible design for X-Pinch Driver:**

**Modification of ISIS Induction Cell Driver**

# ISIS Induction-Cell Driver: 5 Pulse Forming Lines

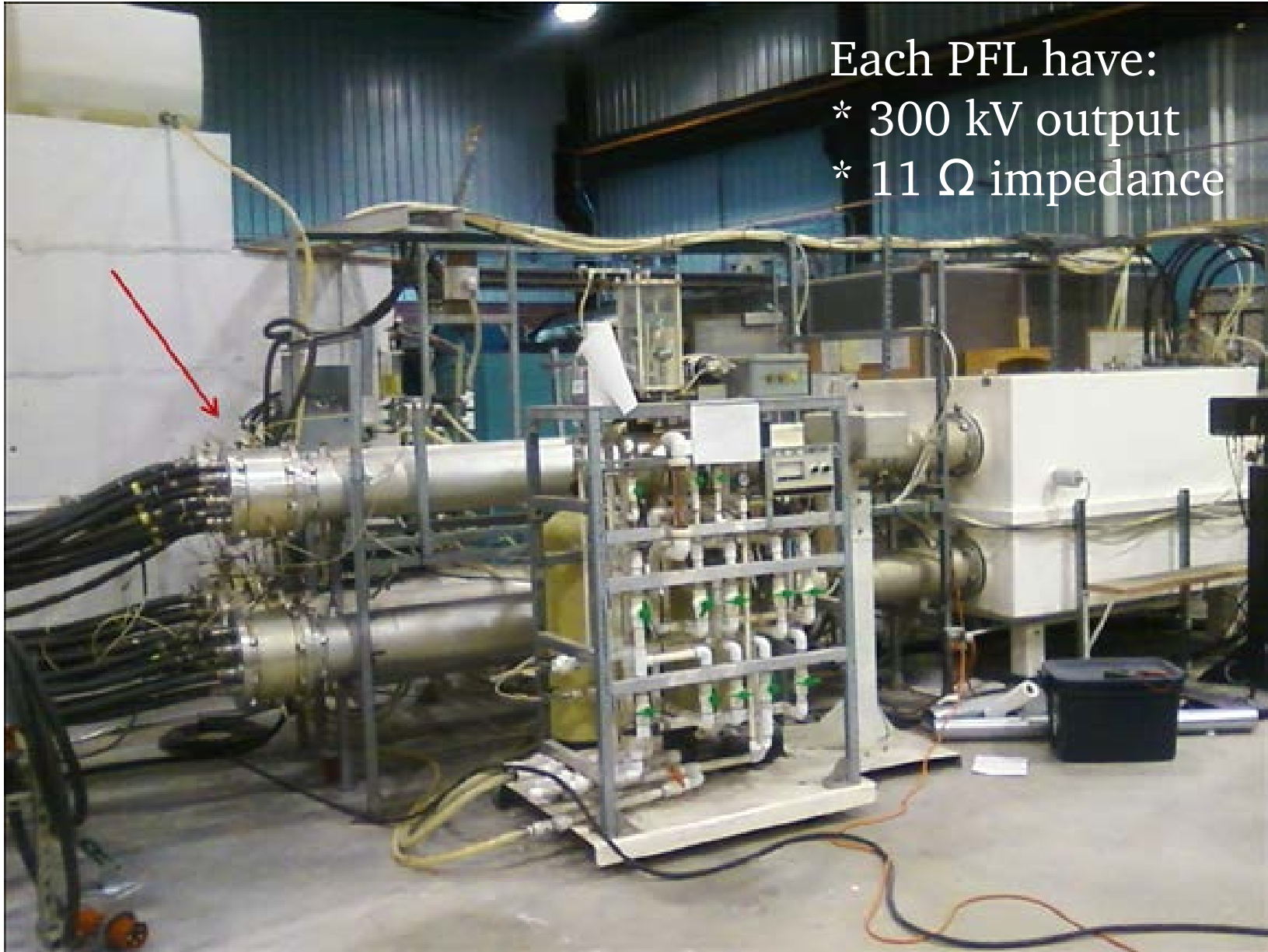

Each PFL have:

\* 300 kV output

\* 11  $\Omega$  impedance

# ISIS Induction-Cell Driver: X Pinch Radiation Source

**Step 1:** Combine five 300 kV Pulse Forming Lines (PFLs) into one low impedance ( $< 1 \text{ Ohm}$ ) output (impedance transformer).

**Step 2.** Fed this transformer into Vacuum Chamber

**Step 3.** Maximize current at X – Pinch

**Design Criteria:** simplicity, low-cost, high reliability, minimize the time to switch between the PRS mode and the normal operation mode of ISIS

# LTSpice Simulation: model

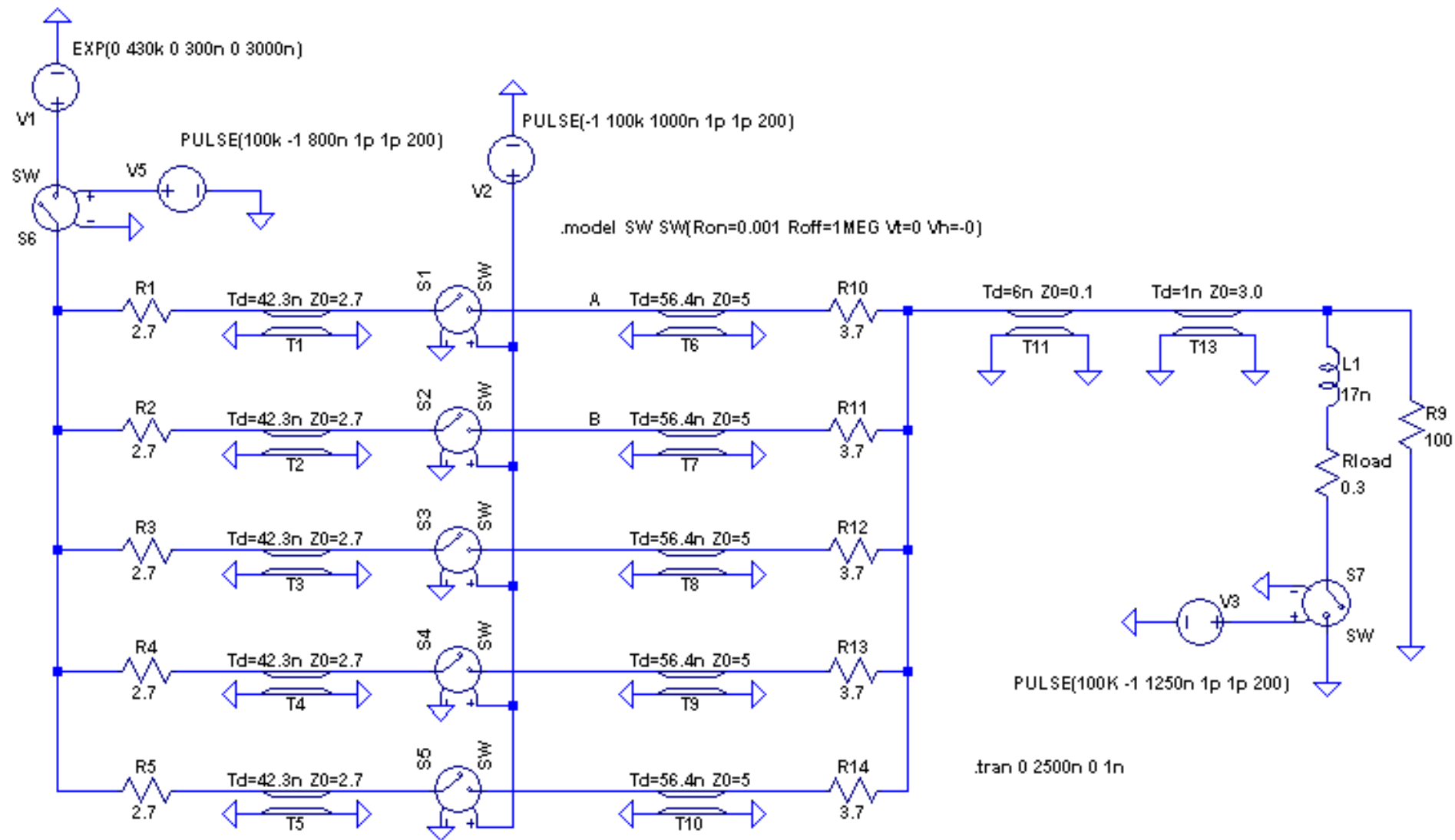



# LTSpice simulation: fire

230 kA current  
100 ns width  
-20 kV at SW

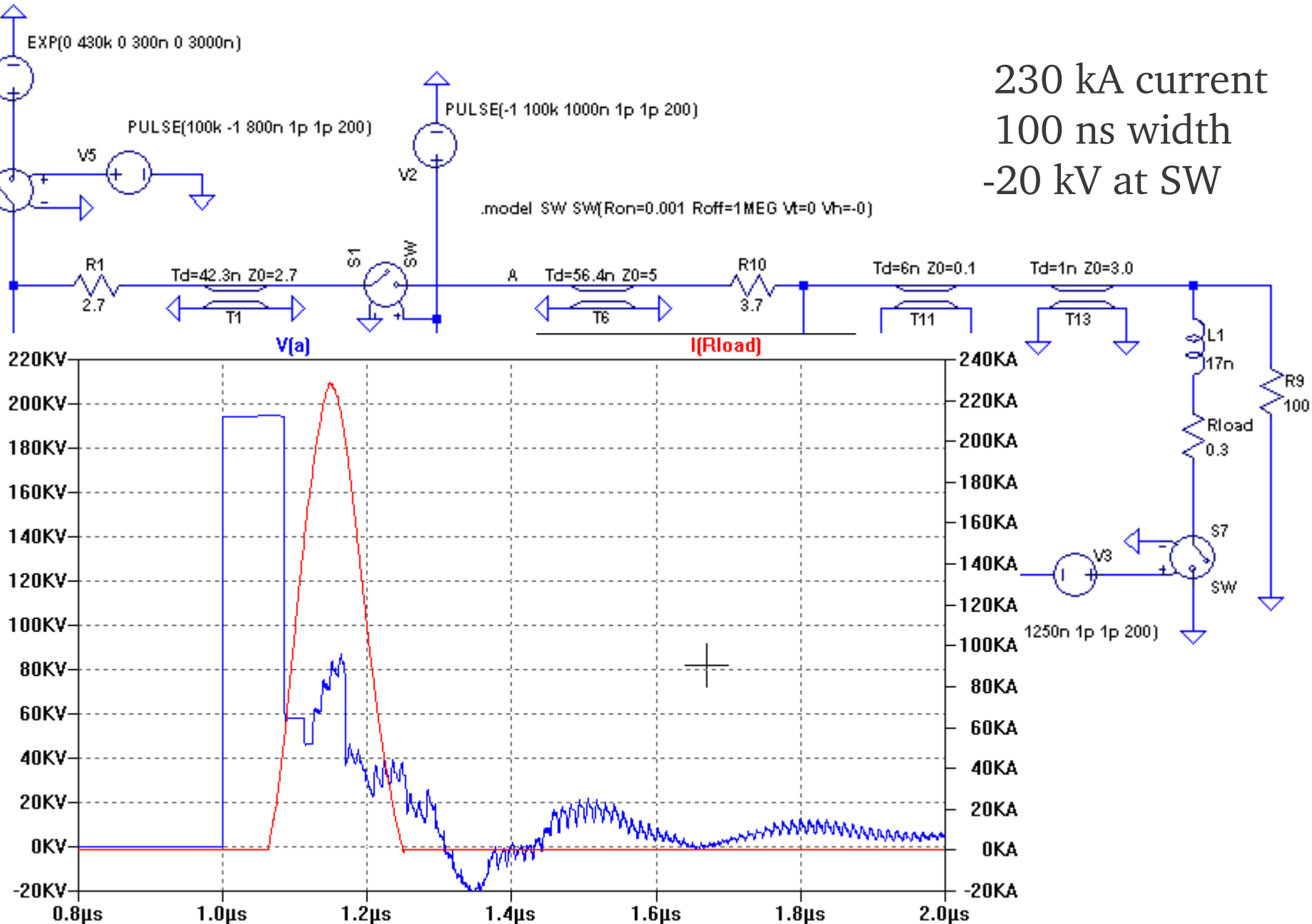

# Modified ISIS Induction-Cell Driver: **Transformer**

$$T = 6 \text{ ns}$$

$$Z_0 = 0.1 \ \Omega$$

## Transformer Length:

$$30 \text{ cm/ns} * 6 \text{ ns} = 180 \text{ cm (in vacuum)}$$

$$180 \text{ cm} / 9 = 20 \text{ cm (in water)}$$

We can do 20 cm long water filled transformer

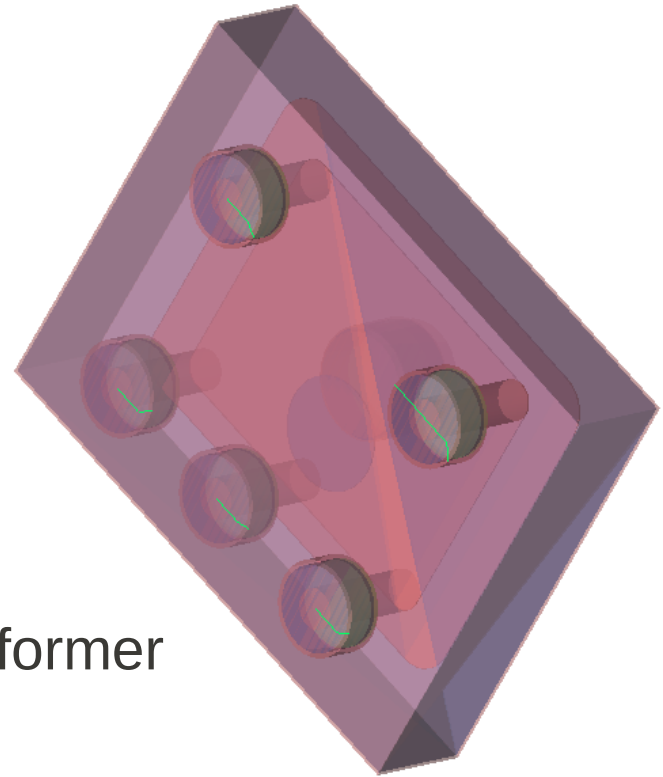

## Transformer Impedance:

$$Z = L/C$$

Challenge to design, but can be done with XFDTD

**2<sup>nd</sup> possible design of X-Pinch Driver:**

**Construct separate Marx generator  
with Pulse Forming Line**

# MARX + Vacuum Chamber

IAC\_Marx\_Chamber

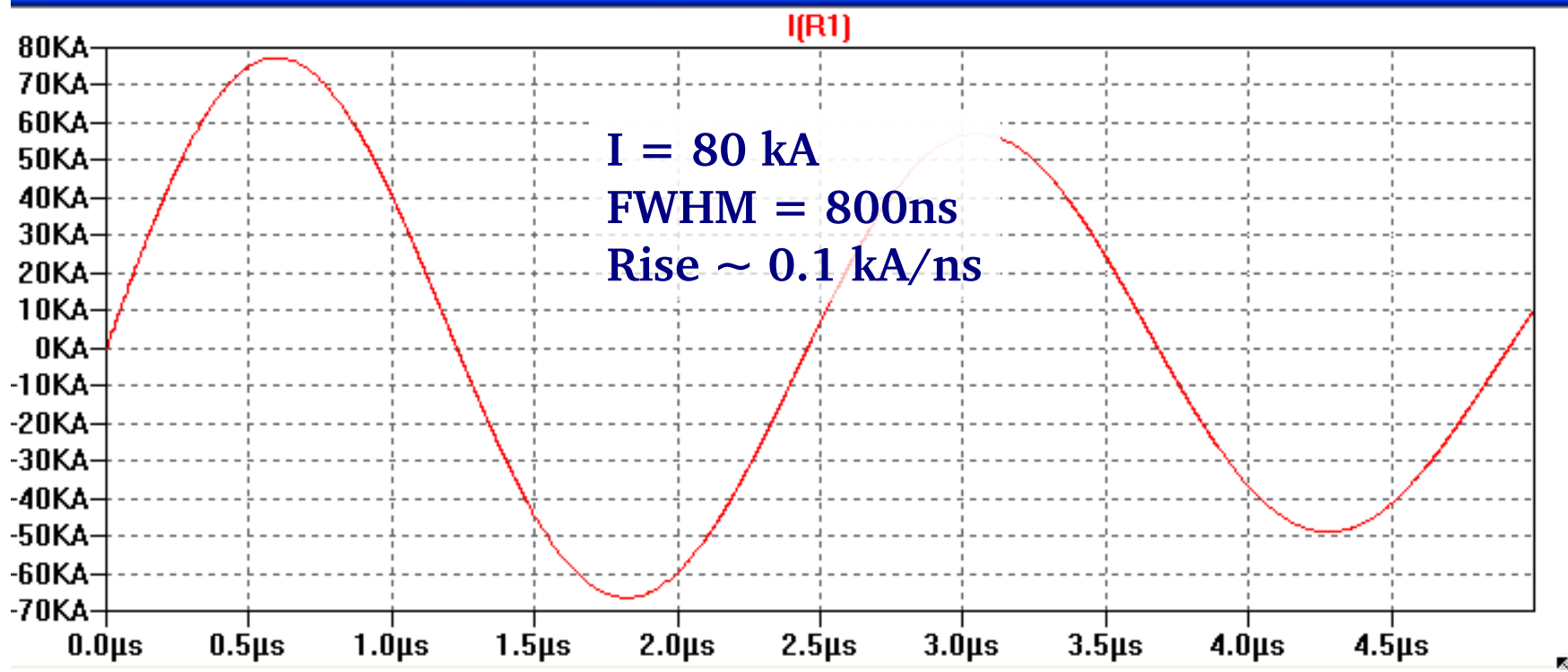
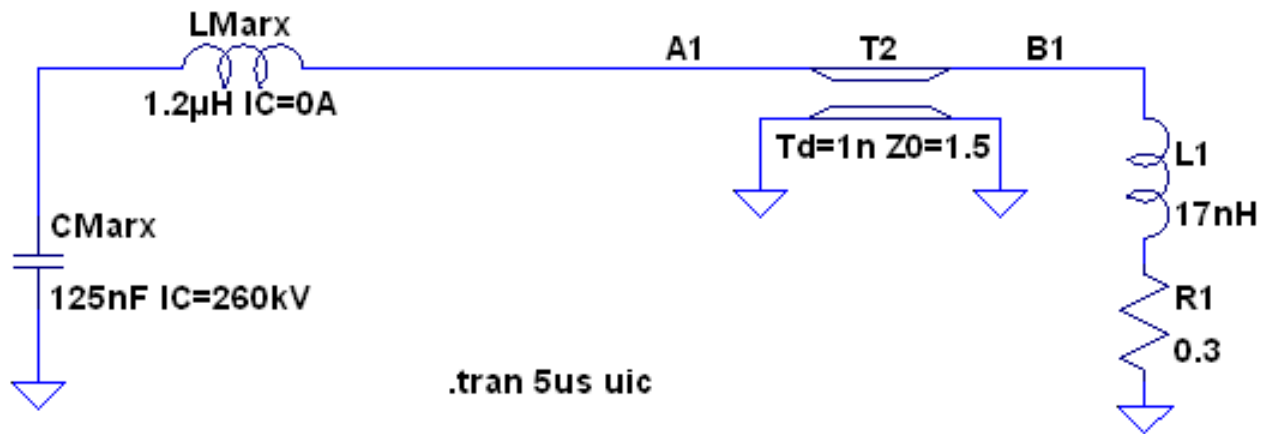

# MARX + one PFL + Switch + Vacuum Chamber

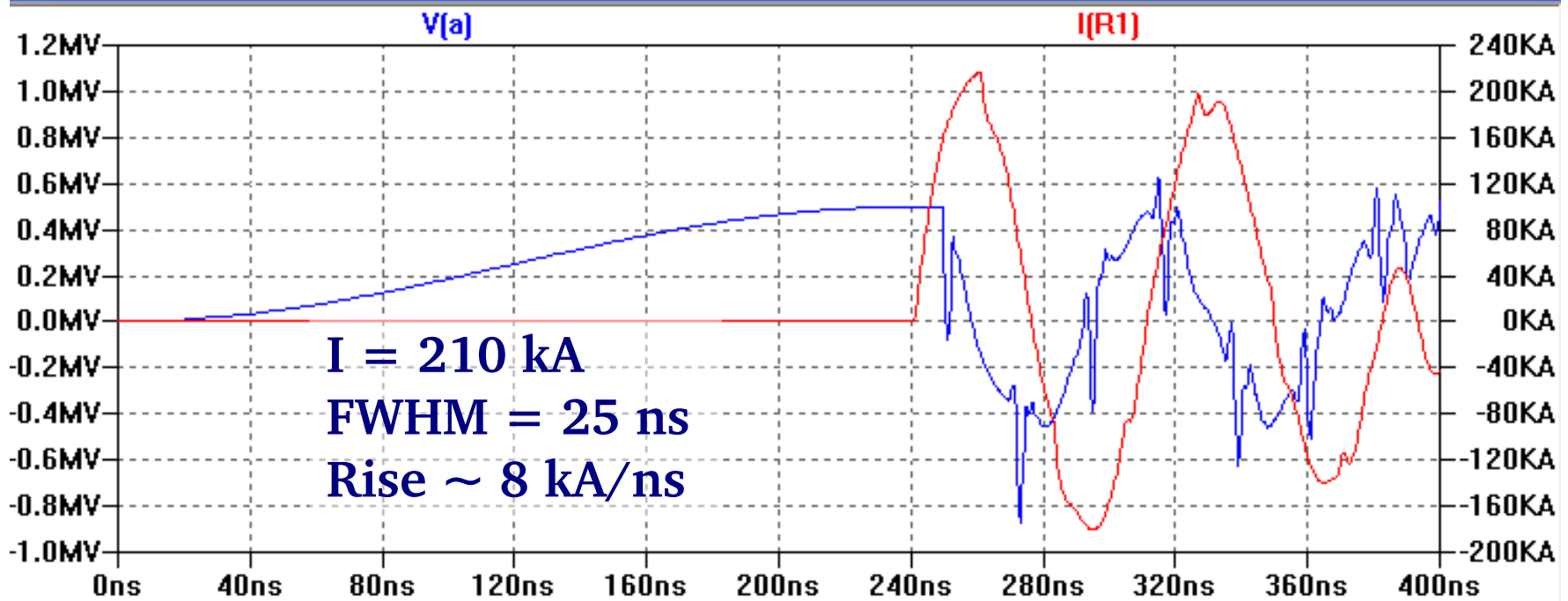
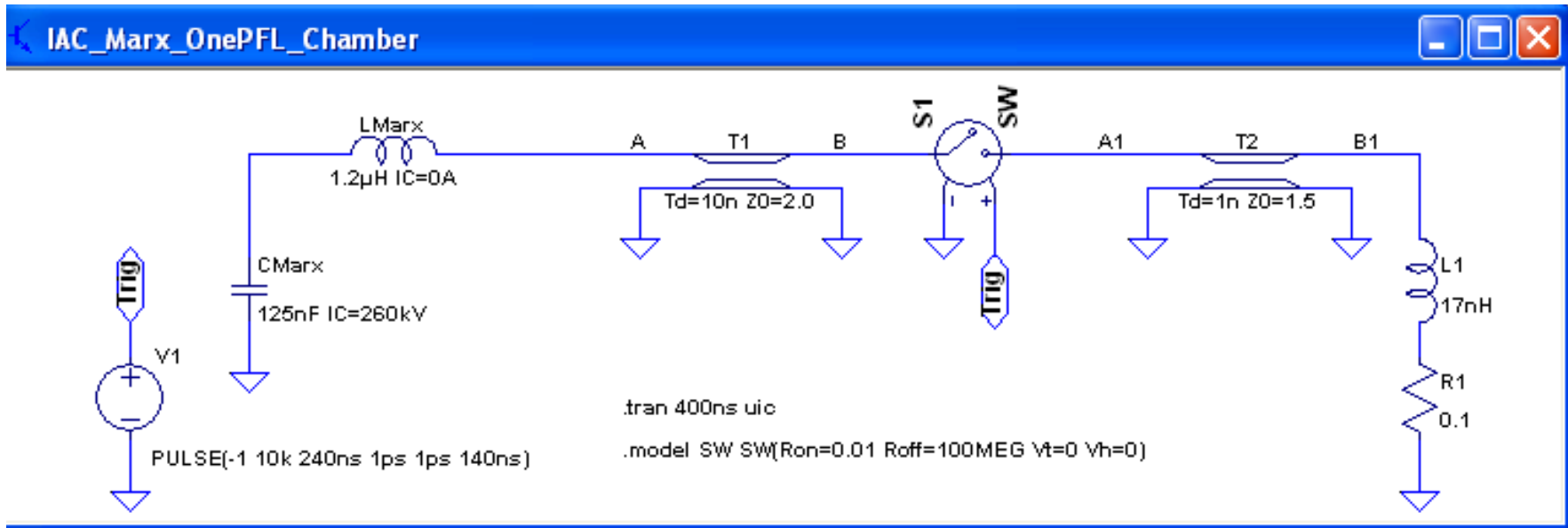

## **3<sup>rd</sup> possible design of X-Pinch Driver:**

**No Marx generator**

**No Pulse Forming Line**

**instead utilize the advantage of**

**a new low inductance**

**capacitors and switches**

**to build a compact PRS**

# LRC circuit basics\*

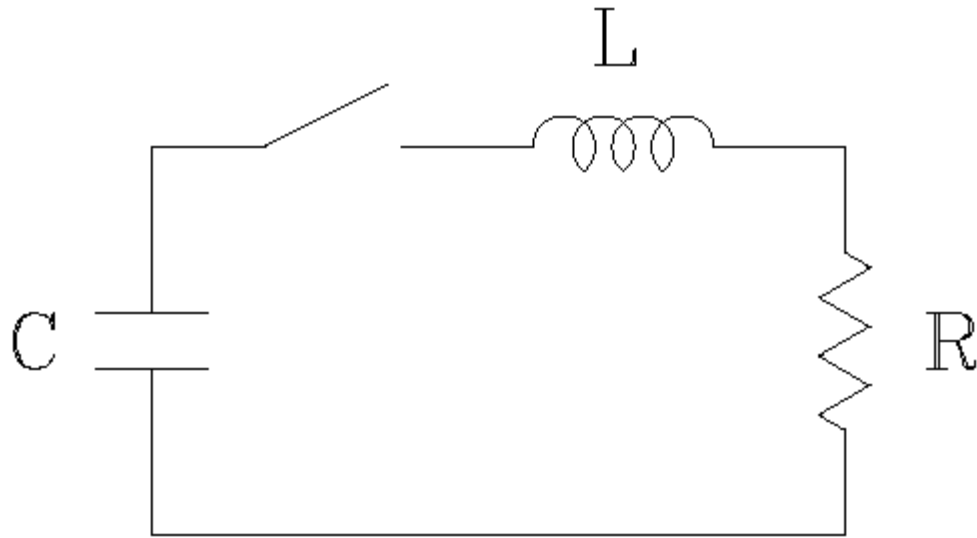

$$L d^2 i / d^2 t + R di / dt + i / C = 0$$

**“Damped”**

$$R = \sqrt{L/C}$$

$$v_{peak} = 0.546293 V_0$$

$$i_{peak} = 0.546293 V_0 / R$$

$$t_{peak} = 1.2092 \sqrt{LC}$$

**“Critical Damped”**

$$R = 2 \sqrt{L/C}$$

$$v_{peak} = 0.73576 V_0$$

$$i_{peak} = 0.73576 V_0 / R$$

$$t_{peak} = \sqrt{LC}$$

\*M.G.Mazarakis, and R.B.Spielman “A compact, high-voltage E-beam pulser” 1999 IEEE

# General Atomics Electronics System: Capacitors\*

## Series PDS/PDSS - Fast Pulse Capacitors



Double-Ended Plastic Case Capacitors  
Low Inductance, Low ESR (0.06 - 0.13  $\Omega$ )  
Sub-microsecond pulse risetime to 100 kV

Part Number	Cap Rating (nF)	Voltage Rating (kV)	Rated Peak Current (kA)	Rated Voltage Reversal (%)	Design Life (at Rated VR)	Operating Temp Range ( $^{\circ}\text{C}$ )	Approx. Inductance (nH)
35460	8	100	25	20	$1 \times 10^5$	-10 to +40	6
35467	20	100	25	10	$1 \times 10^5$	-10 to +40	6
35473	40	100	25	10	$5 \times 10^4$	-10 to +40	10
35479	80	100	25	10	$4 \times 10^4$	-10 to +40	8
35478	80	100	60	30	$5 \times 10^4$	-10 to +40	10
35462	100	100	25	10	$3.4 \times 10^4$	-10 to +40	10
35477	100	100	50	45	$5 \times 10^3$	-10 to +40	10

\*<http://www.ga-esi.com/EP/capacitors/series-pds.php>



# Four capacitors 35478

Capacitor 35477:  $C_c = 80 \text{ nF}$ ,  $L_c = 10 \text{ nH}$ ,  $V_0 = 100 \text{ kV}$ ,  $I_c = 60 \text{ kA}$

Switch:  $L_{sw} = 10 \text{ nH}$

**With 4 such capacitors we can built 200 kA, 0.25  $\Omega$  generator**

$$I_{peak} = 200 \text{ kA}$$

$$V_{peak} = 50 \text{ kV}$$

$$t_{peak} = 97 \text{ ns}$$

$$2.06 \text{ kA/ns}$$

$$L_{load+line} = 15 \text{ nH}$$

$$R_{load} = 0.25 \Omega$$

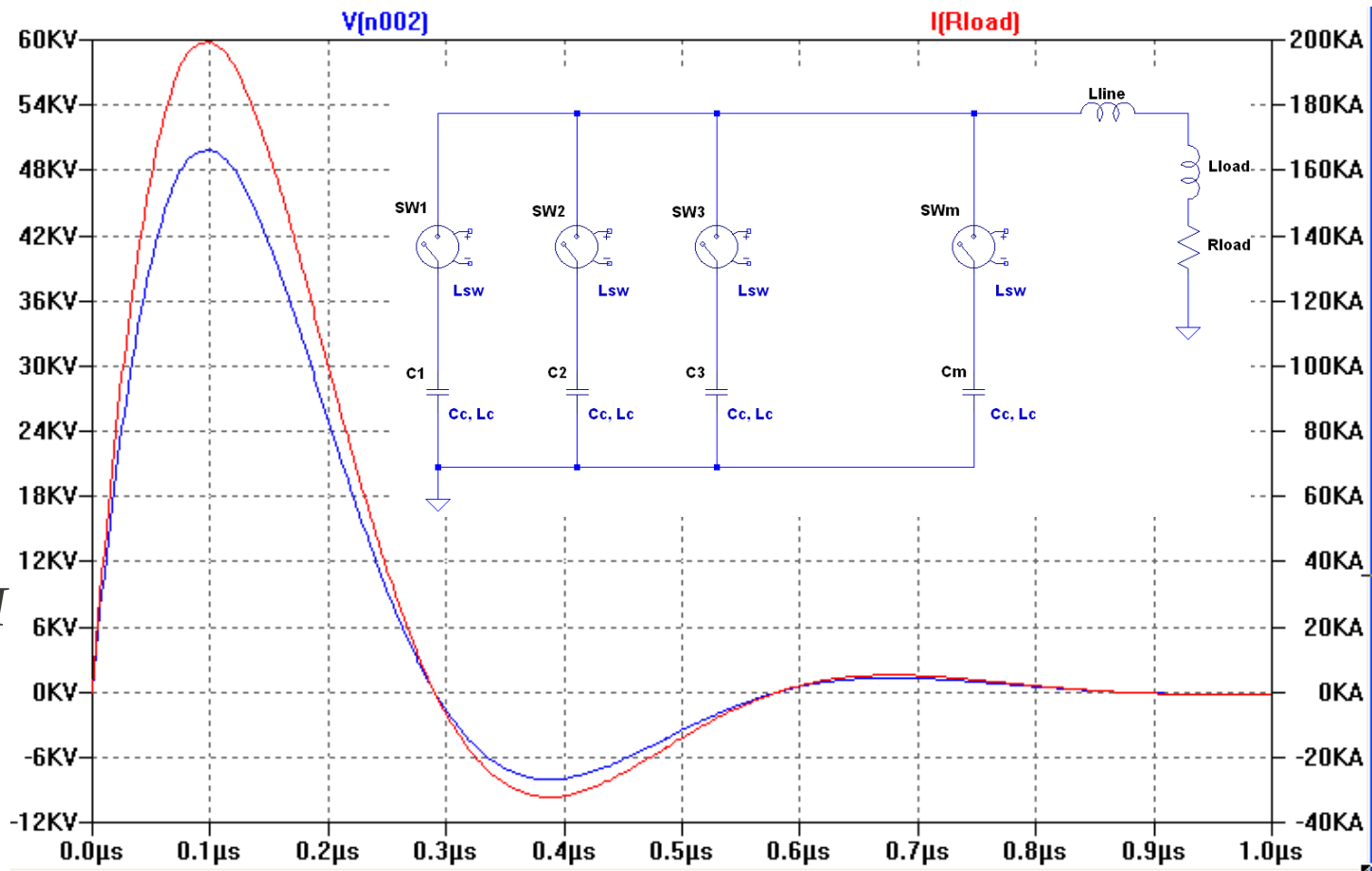

**4<sup>th</sup> possible design of X-Pinch Driver:**

**We can use a complete  
Linear Transformer Driver (LTD) Cavity  
to build X/Z – Pinch Driver**

## Sandia National Laboratory LTD Cavity \*

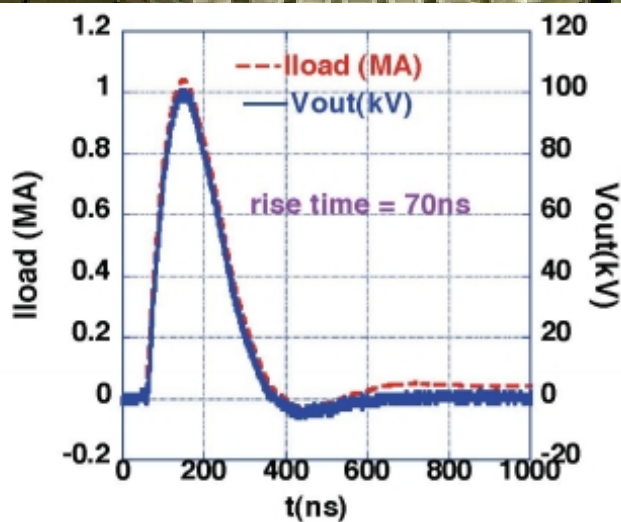
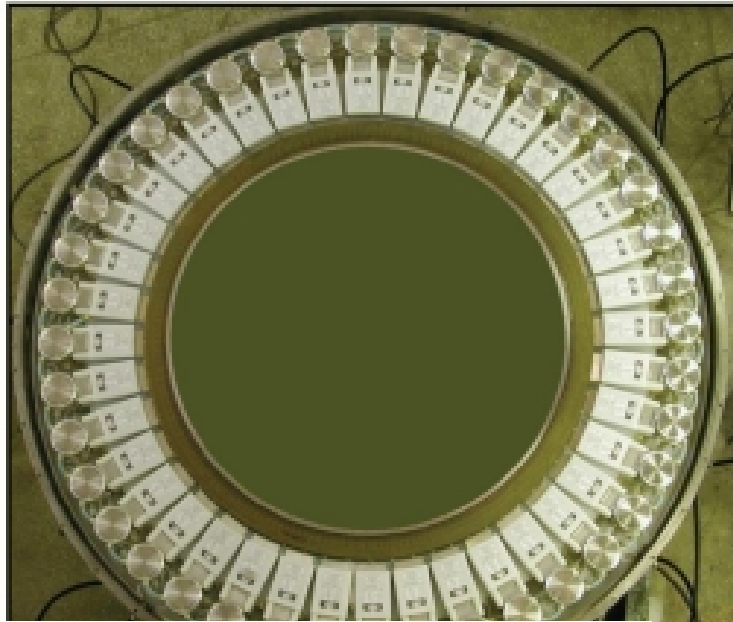

## Institute of High Current Electronics LTD Cavity \*\*

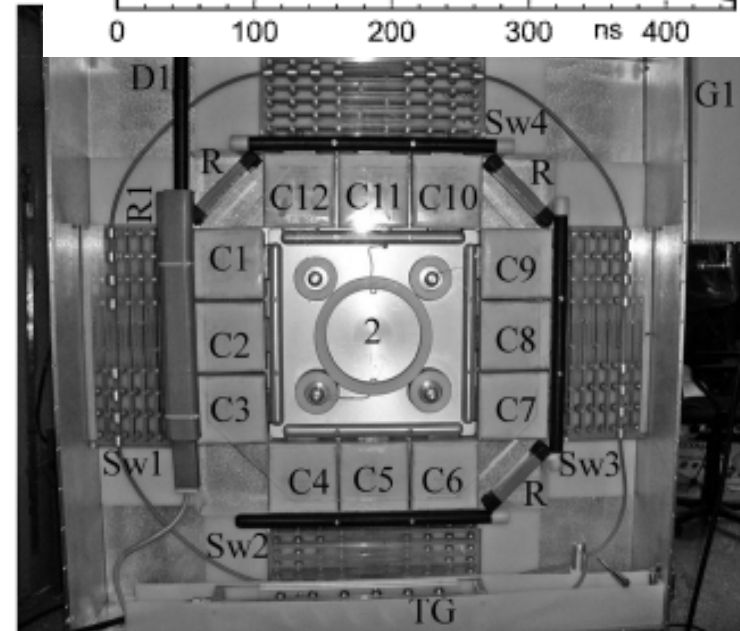
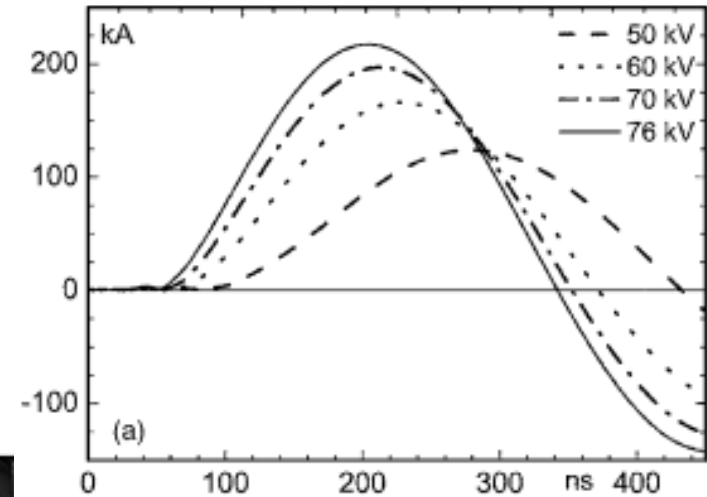

\* Mazarakisaa, M.G. "High Current Fast 100-NS LTD Driver Development in Sandia Laboratory" 2005 IEEE  
 \*\* A. V. Kharlov "Compact high current generator for x-ray radiography" Rev. Sci. Instrum. 77, 123501 (2006)

# Conclusion

1. X /Z – Pinch Driver has many applications in different areas of research, starting from imaging, radiography and ending up with pulsed fusion energy research
2. We can actively participate in Pulsed Power Research by building one or more X/Z – Pinch Driver at IAC
3. At present moment, we can push for different plans:
  - \* Modification of ISIS ICD
  - \* Construction of separate Marx generator + PFL
  - \* Utilize the new low inductance capacitor and switch technologies to build a compact PRS
  - \* Acquire complete LTD cavity for X/Z-Pinch study

**THANK YOU**