

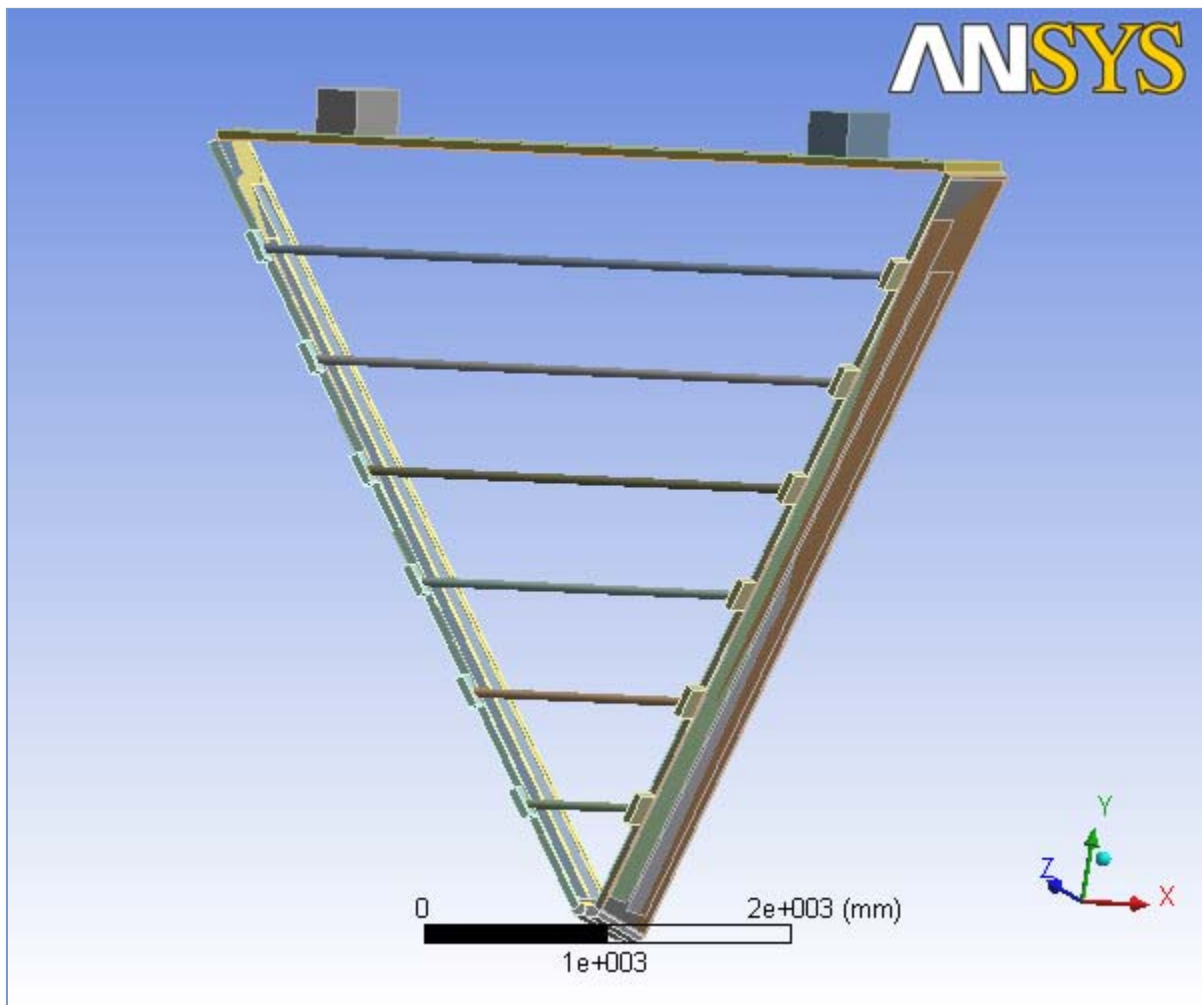

Project

<i>First Saved</i>	<i>Friday, April 25, 2008</i>
<i>Last Saved</i>	<i>Friday, April 25, 2008</i>
<i>Product Version</i>	<i>11.0 Release</i>



Contents

- **Model**
 - [Geometry](#)
 - [Parts](#)
 - [Connections](#)
 - [Contact Regions](#)
 - [Mesh](#)
 - **Static Structural**
 - [Analysis Settings](#)
 - [Acceleration](#)
 - [Loads](#)
 - [Solution](#)
 - [Solution Information](#)
 - [Results](#)
- **Material Data**
 - [Polyurethane](#)
 - [Aluminum](#)
 - [Stainless Steel](#)
 - [Carbon fiber](#)

Units

TABLE 1

Unit System	Metric (mm, kg, N, °C, s, mV, mA)
Angle	Degrees
Rotational Velocity	rad/s

Model

Geometry

TABLE 2
Model > Geometry

Object Name	<i>Geometry</i>
State	Fully Defined
Definition	
Source	C:\Documents and Settings\Jinnuri\Desktop\website\R3_2.agdb
Type	DesignModeler
Length Unit	Millimeters
Element Control	Program Controlled
Display Style	Part Color
Bounding Box	
Length X	4768.3 mm
Length Y	4317.7 mm
Length Z	2060. mm
Properties	
Volume	4.5833e+008 mm ³
Mass	315.09 kg

Statistics	
Bodies	28
Active Bodies	28
Nodes	156969
Elements	24894
Preferences	
Import Solid Bodies	Yes
Import Surface Bodies	Yes
Import Line Bodies	Yes
Parameter Processing	Yes
Personal Parameter Key	DS
CAD Attribute Transfer	No
Named Selection Processing	No
Material Properties Transfer	No
CAD Associativity	Yes
Import Coordinate Systems	No
Reader Save Part File	No
Import Using Instances	Yes
Do Smart Update	No
Attach File Via Temp File	No
Analysis Type	3-D
Mixed Import Resolution	None
Enclosure and Symmetry Processing	Yes

TABLE 3
Model > Geometry > Parts

Object Name	<i>Nose Plate</i>	<i>Left Endplate Downstream Hole area</i>	<i>Right Endplate Upstream Hole area</i>	<i>Left Endplate Upstream Hole area</i>	<i>Left Endplate Aluminum Casing</i>
State	Meshed				
Graphics Properties					
Visible	Yes				
Transparency	1				
Definition					
Suppressed	No				
Material	Polyurethane				Aluminum
Stiffness Behavior	Flexible				
Nonlinear Material Effects	Yes				
Bounding Box					
Length X	180.6 mm	2159.8 mm	2116.2 mm	1973.8 mm	2338.9 mm
Length Y	94.006 mm	3690. mm	3614.6 mm	3368. mm	4000.3 mm
Length Z	529.95 mm	1562.8 mm	1531.7 mm	1437.5 mm	1983.2 mm
Properties					
Volume	6.6319e+006 mm ³	4.3107e+007 mm ³	4.1332e+007 mm ³	3.8462e+007 mm ³	1.1673e+007 mm ³
Mass	1.5917 kg	10.346 kg	9.9198 kg	9.2309 kg	31.518 kg
Centroid X	-1.8724e-016 mm	-1157.7 mm	1145.5 mm	-1057.2 mm	-1178.2 mm
Centroid Y	42.65 mm	1932.5 mm	1911.3 mm	1758.4 mm	1967.9 mm
Centroid Z	-263.29 mm	368. mm	587.1 mm	528.73 mm	639.08 mm

Moment of Inertia Ip1	37968 kg·mm ²	1.68e+007 kg·mm ²	1.5457e+007 kg·mm ²	1.2459e+007 kg·mm ²	5.6821e+007 kg·mm ²
Moment of Inertia Ip2	39504 kg·mm ²	34145 kg·mm ²	31455 kg·mm ²	29271 kg·mm ²	1.6143e+006 kg·mm ²
Moment of Inertia Ip3	3875.8 kg·mm ²	1.677e+007 kg·mm ²	1.543e+007 kg·mm ²	1.2434e+007 kg·mm ²	5.5221e+007 kg·mm ²
Statistics					
Nodes	440	296	272	2445	
Elements	179	24	22	926	

TABLE 4
Model > Geometry > Parts

Object Name	<i>Left Endplate Polyurethane</i>	<i>Right Endplate Downstream Hole area</i>	<i>Right Endplate Aluminum Casing</i>	<i>Right Endplate Polyurethane</i>	<i>Left Endplate Inner Steel slice</i>
State	Meshed				
Graphics Properties					
Visible	Yes				
Transparency	1				
Definition					
Suppressed	No				
Material	Polyurethane		Aluminum	Polyurethane	Stainless Steel
Stiffness Behavior	Flexible				
Nonlinear Material Effects	Yes				
Thickness					1.2192 mm
Thickness Mode					Manual
Bounding Box					
Length X	2327.6 mm	1998.1 mm	2338.8 mm	2322.8 mm	2294.9 mm
Length Y	3980.8 mm	3410. mm	4000.2 mm	3972.4 mm	3974.9 mm
Length Z	1956.7 mm	1457.6 mm	1984. mm	1954.5 mm	1983.2 mm
Properties					
Volume	3.4557e+007 mm ³	3.9784e+007 mm ³	1.1919e+007 mm ³	3.4764e+007 mm ³	2.9149e+006 mm ³
Mass	8.2936 kg	9.5482 kg	32.181 kg	8.3434 kg	23.319 kg
Centroid X	-1396. mm	1078.8 mm	1201.6 mm	1379.8 mm	
Centroid Y	2345.1 mm	1795.8 mm	2008.4 mm	2317.1 mm	
Centroid Z	542.67 mm	316.67 mm	651.27 mm	513.21 mm	
Moment of Inertia Ip1	2.0961e+007 kg·mm ²	1.321e+007 kg·mm ²	6.0236e+007 kg·mm ²	2.1346e+007 kg·mm ²	
Moment of Inertia Ip2	2.0417e+005 kg·mm ²	31513 kg·mm ²	1.6548e+006 kg·mm ²	1.8581e+005 kg·mm ²	
Moment of Inertia Ip3	2.076e+007 kg·mm ²	1.3183e+007 kg·mm ²	5.8594e+007 kg·mm ²	2.1163e+007 kg·mm ²	
Surface Area (approx.)					2.3908e+006 mm ²
Statistics					
Nodes	1862	272	2379	1843	168
Elements	639	22	905	627	124

TABLE 5
Model > Geometry > Parts

Object Name	<i>Left Endplate Outer Steel slice</i>	<i>Right Endplate Outer Steel slice</i>	<i>Right Endplate Inner Steel Slice</i>	<i>Backplate Aluminum Casing</i>	<i>Backplate Polyurethane</i>
State	Meshed				
Graphics Properties					
Visible	Yes				
Transparency	1				
Definition					
Suppressed	No				
Material	Stainless Steel			Aluminum	Polyurethane
Nonlinear Material Effects	Yes				
Thickness	1.2192 mm				
Thickness Mode	Manual				
Stiffness Behavior				Flexible	
Bounding Box					
Length X	2294.9 mm	2294.8 mm		4682.7 mm	4659.3 mm
Length Y	3974.9 mm	3974.8 mm		186.53 mm	180.41 mm
Length Z	1983.2 mm	1984. mm		498.46 mm	476.92 mm
Properties					
Volume	2.9149e+006 mm ³			5.2863e+006 mm ³	1.1124e+008 mm ³
Mass	23.319 kg			14.273 kg	26.698 kg
Surface Area (approx.)	2.3908e+006 mm ²				
Centroid X				175.74 mm	-0.24556 mm
Centroid Y				3986.6 mm	3987.5 mm
Centroid Z				1225.6 mm	1222.4 mm
Moment of Inertia Ip1				7.8718e+005 kg·mm ²	5.1362e+005 kg·mm ²
Moment of Inertia Ip2				3.0219e+007 kg·mm ²	4.725e+007 kg·mm ²
Moment of Inertia Ip3				2.9438e+007 kg·mm ²	4.6748e+007 kg·mm ²
Statistics					
Nodes	176	157	155	708	241
Elements	132	113	111	74	24

TABLE 6
Model > Geometry > Parts

Object Name	<i>Rod 4</i>	<i>Rod 5</i>	<i>Rod 6</i>	<i>Rod 1</i>	<i>Rod 2</i>
State	Meshed				
Graphics Properties					
Visible	Yes				
Transparency	1				
Definition					
Suppressed	No				
Material	Carbon fiber				
Stiffness Behavior	Flexible				
Nonlinear Material Effects	Yes				
Bounding Box					

Length X	2618.1 mm	3260.4 mm	3902.6 mm	691.28 mm	1333.5 mm
Length Y	50.8 mm				
Length Z	50.8 mm				
Properties					
Volume	5.1151e+005 mm ³	6.3841e+005 mm ³	7.6532e+005 mm ³	1.3079e+005 mm ³	2.577e+005 mm ³
Mass	0.29667 kg	0.37028 kg	0.44388 kg	7.586e-002 kg	0.14946 kg
Centroid X	-3.0688e-010 mm	-8.6731e-011 mm	-1.3795e-008 mm	-7.386e-011 mm	5.0812e-010 mm
Centroid Y	2220.1 mm	2776.3 mm	3332.5 mm	551.82 mm	1107.8 mm
Centroid Z	880.31 mm	1091.6 mm	1302.9 mm	246.45 mm	457.74 mm
Moment of Inertia Ip1	177.84 kg·mm ²	221.97 kg·mm ²	266.09 kg·mm ²	45.457 kg·mm ²	89.595 kg·mm ²
Moment of Inertia Ip2	1.6387e+005 kg·mm ²	3.1853e+005 kg·mm ²	5.4867e+005 kg·mm ²	2768.1 kg·mm ²	21001 kg·mm ²
Moment of Inertia Ip3	1.6388e+005 kg·mm ²	3.1853e+005 kg·mm ²	5.4867e+005 kg·mm ²	2768.2 kg·mm ²	21001 kg·mm ²
Statistics					
Nodes	27520	34352	41184	11946	7788
Elements	3920	4896	5872	1760	1104

TABLE 7
Model > Geometry > Parts

Object Name	<i>Rod 3</i>	<i>Force ref line</i>	<i>30 deg Ref line</i>	<i>60 Deg Ref line</i>	<i>Left Hinge</i>
State	Meshed				
Graphics Properties					
Visible	Yes				
Transparency	1				
Definition					
Suppressed	No				
Material	Carbon fiber	Polyurethane			
Stiffness Behavior	Flexible				
Nonlinear Material Effects	Yes				
Bounding Box					
Length X	1975.8 mm	70. mm	11.116 mm	20.123 mm	250.37 mm
Length Y	50.8 mm	3.6786 mm	19.253 mm	11.618 mm	371.11 mm
Length Z	50.8 mm	5. mm			528.13 mm
Properties					
Volume	3.846e+005 mm ³	643.76 mm ³	535.05 mm ³	584.49 mm ³	2.9863e+007 mm ³
Mass	0.22307 kg	1.545e-004 kg	1.2841e-004 kg	1.4028e-004 kg	7.1671 kg
Centroid X	-5.8382e-011 mm	2.7078e-014 mm	-3.7053 mm	-6.7077 mm	-1527.6 mm
Centroid Y	1663.9 mm	68.426 mm	39.079 mm	13.673 mm	4131.5 mm
Centroid Z	669.03 mm	2.5 mm			1265.9 mm
Moment of Inertia Ip1	133.72 kg·mm ²	4.3804e-004 kg·mm ²	3.1967e-003 kg·mm ²	1.0045e-003 kg·mm ²	1.7368e+005 kg·mm ²
Moment of Inertia Ip2	69702 kg·mm ²	3.1866e-002 kg·mm ²	8.6441e-004 kg·mm ²	3.7877e-003 kg·mm ²	1.7368e+005 kg·mm ²
Moment of Inertia Ip3	69702 kg·mm ²	3.1661e-002 kg·mm ²	3.526e-003 kg·mm ²	4.2077e-003 kg·mm ²	74658 kg·mm ²

Statistics					
Nodes	20576	237	294	250	376
Elements	2928	22	38	30	54

TABLE 8
Model > Geometry > Parts

Object Name	<i>Right Hinge</i>	<i>Backplate Outer steel slice</i>	<i>Back Plate Inner Steel slice</i>
State	Meshed		
Graphics Properties			
Visible	Yes		
Transparency	1		
Definition			
Suppressed	No		
Material	Polyurethane	Stainless Steel	
Stiffness Behavior	Flexible		
Nonlinear Material Effects	Yes		
Thickness		1.2192 mm	
Thickness Mode		Manual	
Bounding Box			
Length X	250.37 mm	4524.4 mm	
Length Y	371.11 mm	137.65 mm	
Length Z	528.13 mm	484.52 mm	
Properties			
Volume	2.9863e+007 mm ³	2.7483e+006 mm ³	
Mass	7.1671 kg	21.987 kg	
Centroid X	1521.8 mm		
Centroid Y	4132.1 mm		
Centroid Z	1263.7 mm		
Moment of Inertia Ip1	1.7368e+005 kg-mm ²		
Moment of Inertia Ip2	1.7368e+005 kg-mm ²		
Moment of Inertia Ip3	74658 kg-mm ²		
Surface Area(approx.)		2.2542e+006 mm ²	
Statistics			
Nodes	376	174	186
Elements	54	129	141

Connections

TABLE 9
Model > Connections

Object Name	<i>Connections</i>
State	Fully Defined
Auto Detection	
Generate Contact On Update	Yes
Tolerance Type	Slider
Tolerance Slider	0.
Tolerance Value	16.886 mm
Face/Face	Yes
Face/Edge	No
Edge/Edge	No
Priority	Include All

Same Body Grouping	Yes
Revolute Joints	Yes
Fixed Joints	Yes
Transparency	
Enabled	Yes

TABLE 10
Model > Connections > Contact Regions

Object Name	Contact Region	Contact Region 2	Contact Region 3	Contact Region 4	Contact Region 5
State	Fully Defined				
Scope					
Scoping Method	Geometry Selection				
Contact	2 Faces				1 Face
Target	2 Faces				1 Face
Contact Bodies	Nose Plate				
Target Bodies	Left Endplate Aluminum Casing	Left Endplate Polyurethane	Right Endplate Aluminum Casing	Right Endplate Polyurethane	Left Endplate Inner Steel slice
Definition					
Type	Bonded				
Scope Mode	Automatic				
Behavior	Symmetric				
Suppressed	No				
Advanced					
Formulation	Pure Penalty				
Normal Stiffness	Program Controlled				
Update Stiffness	Never				
Thermal Conductance	Program Controlled				
Pinball Region	Program Controlled				

TABLE 11
Model > Connections > Contact Regions

Object Name	Contact Region 6	Contact Region 7	Contact Region 8	Contact Region 9	Contact Region 10
State	Fully Defined				
Scope					
Scoping Method	Geometry Selection				
Contact	1 Face				4 Faces
Target	1 Face				4 Faces
Contact Bodies	Nose Plate				Left Endplate Downstream Hole area
Target Bodies	Right Endplate Inner Steel Slice	Force ref line	30 deg Ref line	60 Deg Ref line	Left Endplate Polyurethane
Definition					
Type	Bonded				
Scope Mode	Automatic				
Behavior	Symmetric				
Suppressed	No				
Advanced					

Formulation	Pure Penalty
Normal Stiffness	Program Controlled
Update Stiffness	Never
Thermal Conductance	Program Controlled
Pinball Region	Program Controlled

TABLE 12
Model > Connections > Contact Regions

Object Name	Contact Region 11	Contact Region 12	Contact Region 13	Contact Region 14	Contact Region 15
State	Fully Defined				
Scope					
Scoping Method	Geometry Selection				
Contact	1 Face		4 Faces		1 Face
Target	1 Face		4 Faces		1 Face
Contact Bodies	Left Endplate Downstream Hole area		Right Endplate Upstream Hole area		
Target Bodies	Left Endplate Inner Steel slice	Left Endplate Outer Steel slice	Right Endplate Aluminum Casing	Right Endplate Polyurethane	Right Endplate Outer Steel slice
Definition					
Type	Bonded				
Scope Mode	Automatic				
Behavior	Symmetric				
Suppressed	No				
Advanced					
Formulation	Pure Penalty				
Normal Stiffness	Program Controlled				
Update Stiffness	Never				
Thermal Conductance	Program Controlled				
Pinball Region	Program Controlled				

TABLE 13
Model > Connections > Contact Regions

Object Name	Contact Region 16	Contact Region 17	Contact Region 18	Contact Region 19	Contact Region 20
State	Fully Defined				
Scope					
Scoping Method	Geometry Selection				
Contact	1 Face		4 Faces		1 Face
Target	1 Face		4 Faces		1 Face
Contact Bodies	Right Endplate Upstream Hole area	Left Endplate Upstream Hole area			
Target Bodies	Right Endplate Inner Steel Slice	Left Endplate Aluminum Casing	Left Endplate Polyurethane	Left Endplate Inner Steel slice	Left Endplate Outer Steel slice
Definition					
Type	Bonded				
Scope Mode	Automatic				
Behavior	Symmetric				
Suppressed	No				

Advanced	
Formulation	Pure Penalty
Normal Stiffness	Program Controlled
Update Stiffness	Never
Thermal Conductance	Program Controlled
Pinball Region	Program Controlled

TABLE 14
Model > Connections > Contact Regions

Object Name	<i>Contact Region 21</i>	<i>Contact Region 22</i>	<i>Contact Region 23</i>	<i>Contact Region 24</i>	<i>Contact Region 25</i>
State	Fully Defined				
Scope					
Scoping Method	Geometry Selection				
Contact	4 Faces	1 Face			
Target	4 Faces	1 Face			
Contact Bodies	Left Endplate Aluminum Casing				
Target Bodies	Left Endplate Polyurethane	Left Endplate Inner Steel slice	Left Endplate Outer Steel slice	Rod 4	Rod 5
Definition					
Type	Bonded				
Scope Mode	Automatic				
Behavior	Symmetric				
Suppressed	No				
Advanced					
Formulation	Pure Penalty				
Normal Stiffness	Program Controlled				
Update Stiffness	Never				
Thermal Conductance	Program Controlled				
Pinball Region	Program Controlled				

TABLE 15
Model > Connections > Contact Regions

Object Name	<i>Contact Region 26</i>	<i>Contact Region 27</i>	<i>Contact Region 28</i>	<i>Contact Region 29</i>	<i>Contact Region 30</i>
State	Fully Defined				
Scope					
Scoping Method	Geometry Selection				
Contact	1 Face				
Target	1 Face				
Contact Bodies	Left Endplate Aluminum Casing				Left Endplate Polyurethane
Target Bodies	Rod 6	Rod 1	Rod 2	Rod 3	Left Endplate Inner Steel slice
Definition					
Type	Bonded				
Scope Mode	Automatic				
Behavior	Symmetric				
Suppressed	No				
Advanced					

Formulation	Pure Penalty
Normal Stiffness	Program Controlled
Update Stiffness	Never
Thermal Conductance	Program Controlled
Pinball Region	Program Controlled

TABLE 16
Model > Connections > Contact Regions

Object Name	<i>Contact Region 31</i>	<i>Contact Region 32</i>	<i>Contact Region 33</i>	<i>Contact Region 34</i>	<i>Contact Region 35</i>
State	Fully Defined				
Scope					
Scoping Method	Geometry Selection				
Contact	1 Face	4 Faces	1 Face		4 Faces
Target	1 Face	4 Faces	1 Face		4 Faces
Contact Bodies	Left Endplate Polyurethane	Right Endplate Downstream Hole area			Right Endplate Aluminum Casing
Target Bodies	Left Endplate Outer Steel slice	Right Endplate Polyurethane	Right Endplate Outer Steel slice	Right Endplate Inner Steel Slice	Right Endplate Polyurethane
Definition					
Type	Bonded				
Scope Mode	Automatic				
Behavior	Symmetric				
Suppressed	No				
Advanced					
Formulation	Pure Penalty				
Normal Stiffness	Program Controlled				
Update Stiffness	Never				
Thermal Conductance	Program Controlled				
Pinball Region	Program Controlled				

TABLE 17
Model > Connections > Contact Regions

Object Name	<i>Contact Region 36</i>	<i>Contact Region 37</i>	<i>Contact Region 38</i>	<i>Contact Region 39</i>	<i>Contact Region 40</i>
State	Fully Defined				
Scope					
Scoping Method	Geometry Selection				
Contact	1 Face				
Target	1 Face				
Contact Bodies	Right Endplate Aluminum Casing				
Target Bodies	Right Endplate Outer Steel slice	Right Endplate Inner Steel Slice	Rod 4	Rod 5	Rod 6
Definition					
Type	Bonded				
Scope Mode	Automatic				
Behavior	Symmetric				

Suppressed	No
Advanced	
Formulation	Pure Penalty
Normal Stiffness	Program Controlled
Update Stiffness	Never
Thermal Conductance	Program Controlled
Pinball Region	Program Controlled

TABLE 18
Model > Connections > Contact Regions

Object Name	<i>Contact Region 41</i>	<i>Contact Region 42</i>	<i>Contact Region 43</i>	<i>Contact Region 44</i>	<i>Contact Region 45</i>
State	Fully Defined				
Scope					
Scoping Method	Geometry Selection				
Contact	1 Face				
Target	1 Face				
Contact Bodies	Right Endplate Aluminum Casing			Right Endplate Polyurethane	
Target Bodies	Rod 1	Rod 2	Rod 3	Right Endplate Outer Steel slice	Right Endplate Inner Steel Slice
Definition					
Type	Bonded				
Scope Mode	Automatic				
Behavior	Symmetric				
Suppressed	No				
Advanced					
Formulation	Pure Penalty				
Normal Stiffness	Program Controlled				
Update Stiffness	Never				
Thermal Conductance	Program Controlled				
Pinball Region	Program Controlled				

TABLE 19
Model > Connections > Contact Regions

Object Name	<i>Contact Region 46</i>	<i>Contact Region 47</i>	<i>Contact Region 48</i>	<i>Contact Region 49</i>	<i>Contact Region 50</i>
State	Fully Defined				
Scope					
Scoping Method	Geometry Selection				
Contact	4 Faces	2 Faces		1 Face	
Target	4 Faces	2 Faces		1 Face	
Contact Bodies	Backplate Aluminum Casing			Backplate Polyurethane	
Target Bodies	Backplate Polyurethane	Left Hinge	Right Hinge	Left Hinge	Right Hinge
Definition					
Type	Bonded				
Scope Mode	Automatic				
Behavior	Symmetric				
Suppressed	No				
Advanced					

Formulation	Pure Penalty
Normal Stiffness	Program Controlled
Update Stiffness	Never
Thermal Conductance	Program Controlled
Pinball Region	Program Controlled

TABLE 20
Model > Connections > Contact Regions

Object Name	Contact Region 51	Contact Region 52	Contact Region 53	Contact Region 54	Contact Region 55
State	Fully Defined				
Scope					
Scoping Method	Geometry Selection				
Contact	1 Face				
Target	1 Face				
Contact Bodies	Backplate Aluminum Casing		Backplate Polyurethane		Left Hinge
Target Bodies	Backplate Outer steel slice	Back Plate Inner Steel slice	Backplate Outer steel slice	Back Plate Inner Steel slice	Backplate Outer steel slice
Definition					
Type	Bonded				
Scope Mode	Automatic				
Behavior	Symmetric				
Suppressed	No				
Advanced					
Formulation	Pure Penalty				
Normal Stiffness	Program Controlled				
Update Stiffness	Never				
Thermal Conductance	Program Controlled				
Pinball Region	Program Controlled				

TABLE 21
Model > Connections > Contact Regions

Object Name	Contact Region 56	<i>Bonded - Backplate Aluminum Casing To Left Endplate Aluminum Casing</i>	<i>Bonded - Backplate Aluminum Casing To Right Endplate Aluminum Casing</i>
State	Fully Defined		
Scope			
Scoping Method	Geometry Selection		
Contact	1 Face	1 Edge	
Target	1 Face	1 Edge	
Contact Bodies	Right Hinge	Backplate Aluminum Casing	
Target Bodies	Backplate Outer steel slice	Left Endplate Aluminum Casing	Right Endplate Aluminum Casing
Definition			
Type	Bonded		
Scope Mode	Automatic	Manual	
Behavior	Symmetric		
Suppressed	No		
Advanced			
Formulation	Pure Penalty		

Normal Stiffness	Program Controlled
Update Stiffness	Never
Thermal Conductance	Program Controlled
Pinball Region	Program Controlled

Mesh

TABLE 22
Model > Mesh

Object Name	<i>Mesh</i>
State	Solved
Defaults	
Physics Preference	Mechanical
Relevance	-35
Advanced	
Relevance Center	Coarse
Element Size	Default
Shape Checking	Standard Mechanical
Solid Element Midside Nodes	Program Controlled
Straight Sided Elements	No
Initial Size Seed	Active Assembly
Smoothing	Low
Transition	Fast
Statistics	
Nodes	156969
Elements	24894

Static Structural

TABLE 23
Model > Analysis

Object Name	<i>Static Structural</i>
State	Fully Defined
Definition	
Physics Type	Structural
Analysis Type	Static Structural
Options	
Reference Temp	22. °C

TABLE 24
Model > Static Structural > Analysis Settings

Object Name	<i>Analysis Settings</i>
State	Fully Defined
Step Controls	
Number Of Steps	1.
Current Step Number	1.
Step End Time	1. s
Auto Time Stepping	Program Controlled
Solver Controls	

Solver Type	Direct
Weak Springs	Program Controlled
Large Deflection	Off
Inertia Relief	Off
Nonlinear Controls	
Force Convergence	Program Controlled
Moment Convergence	Program Controlled
Displacement Convergence	Program Controlled
Rotation Convergence	Program Controlled
Line Search	Program Controlled
Output Controls	
Calculate Stress	Yes
Calculate Strain	Yes
Calculate Results At	All Time Points
Analysis Data Management	
Solver Files Directory	C:\Documents and Settings\Jinnuri\Desktop\website\R3_2 Simulation Files\Static Structural (3)\
Future Analysis	None
Save ANSYS db	No
Delete Unneeded Files	Yes
Nonlinear Solution	No

FIGURE 1
Model > Static Structural > Figure

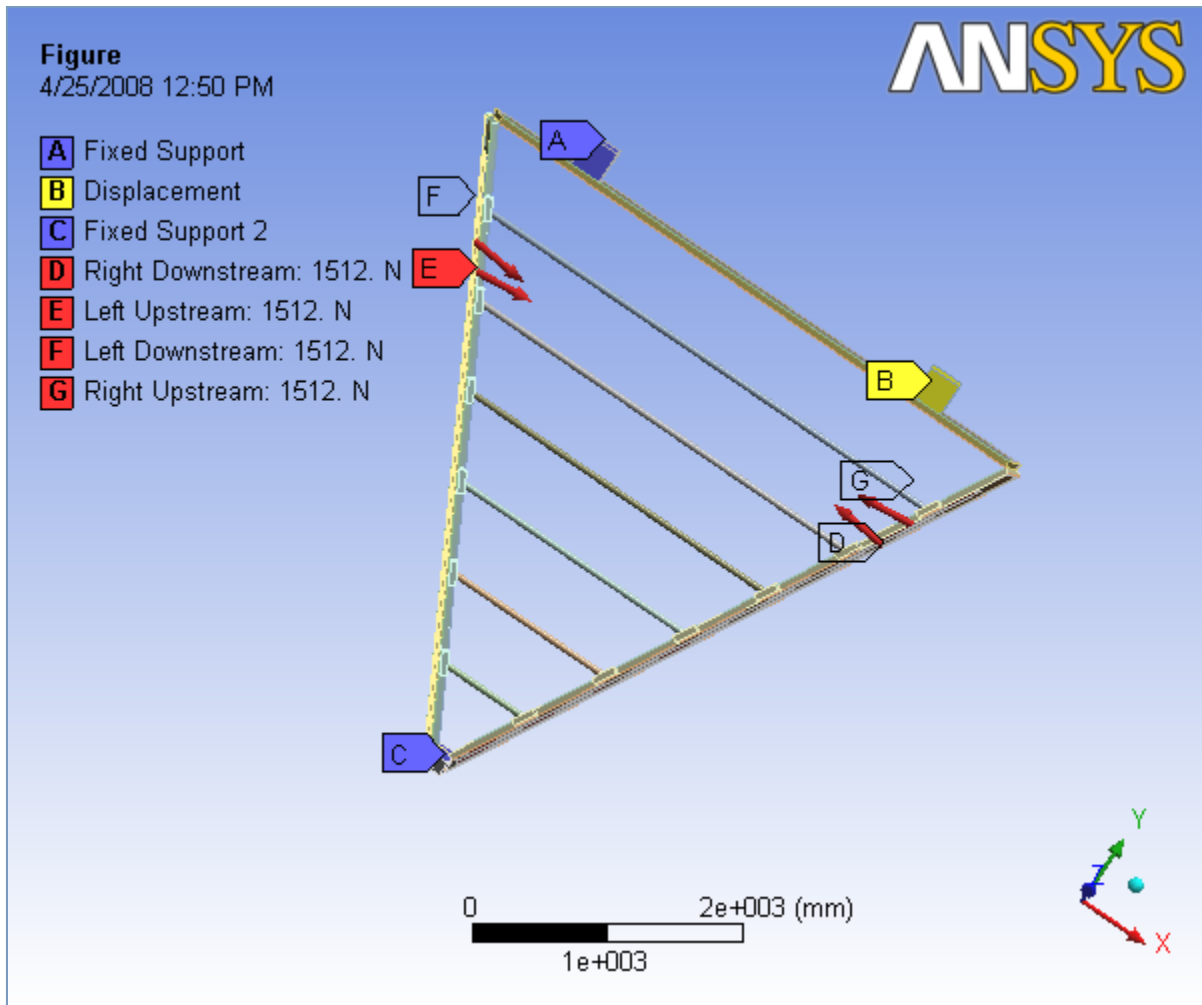
**TABLE 25****Model > Static Structural > Accelerations**

Object Name	<i>Acceleration</i>
State	Suppressed
Scope	
Geometry	All Bodies
Definition	
Define By	Vector
Magnitude	9810. mm/s ² (ramped)
Direction	Defined
Suppressed	Yes

FIGURE 2**Model > Static Structural > Acceleration**

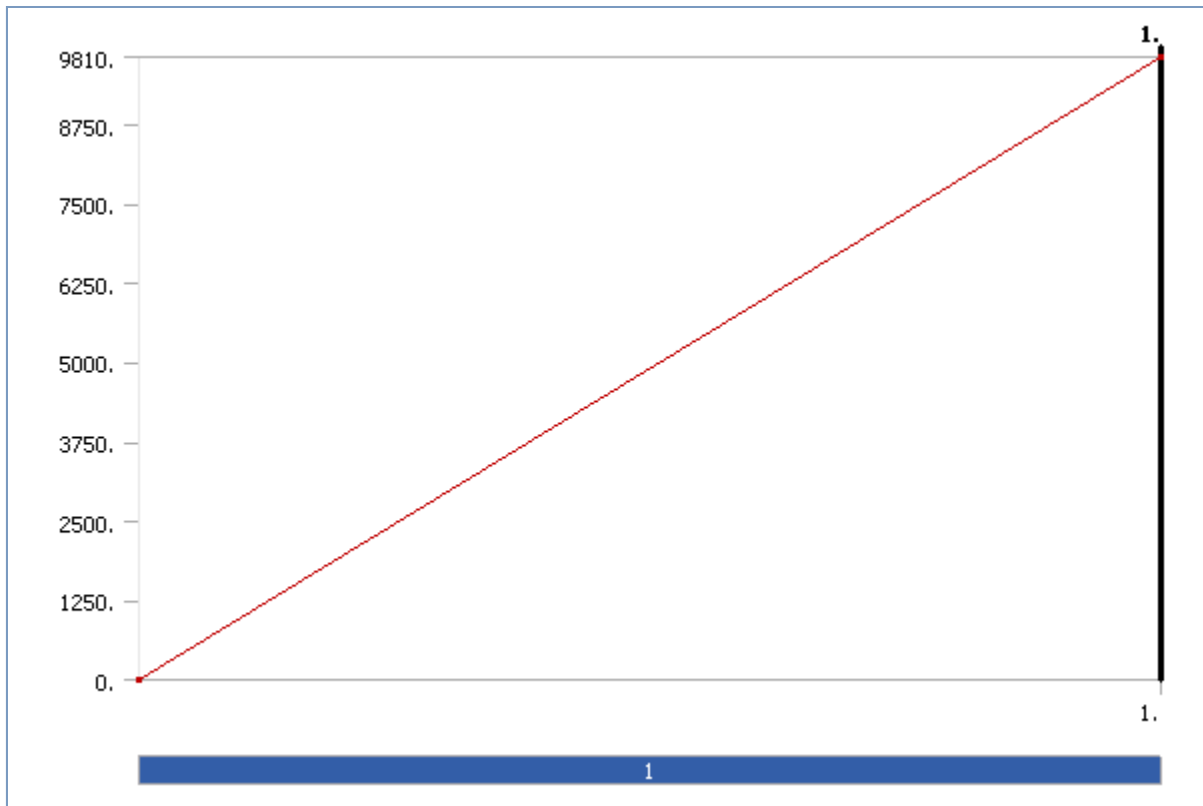

TABLE 26
Model > Static Structural > Loads

Object Name	<i>Fixed Support</i>	<i>Fixed Support 2</i>	<i>Displacement</i>	<i>Right Upstream</i>	<i>Right Downstream</i>
State	Fully Defined				
Scope					
Scoping Method	Geometry Selection				
Geometry	5 Faces	1 Face	5 Faces	1 Face	
Definition					
Type	Fixed Support		Displacement	Force	
Suppressed	No				
Define By			Components	Vector	
X Component			Free		
Y Component			0. mm (ramped)		
Z Component			0. mm (ramped)		
Magnitude				1512. N (ramped)	
Direction				Defined	

FIGURE 3
Model > Static Structural > Displacement

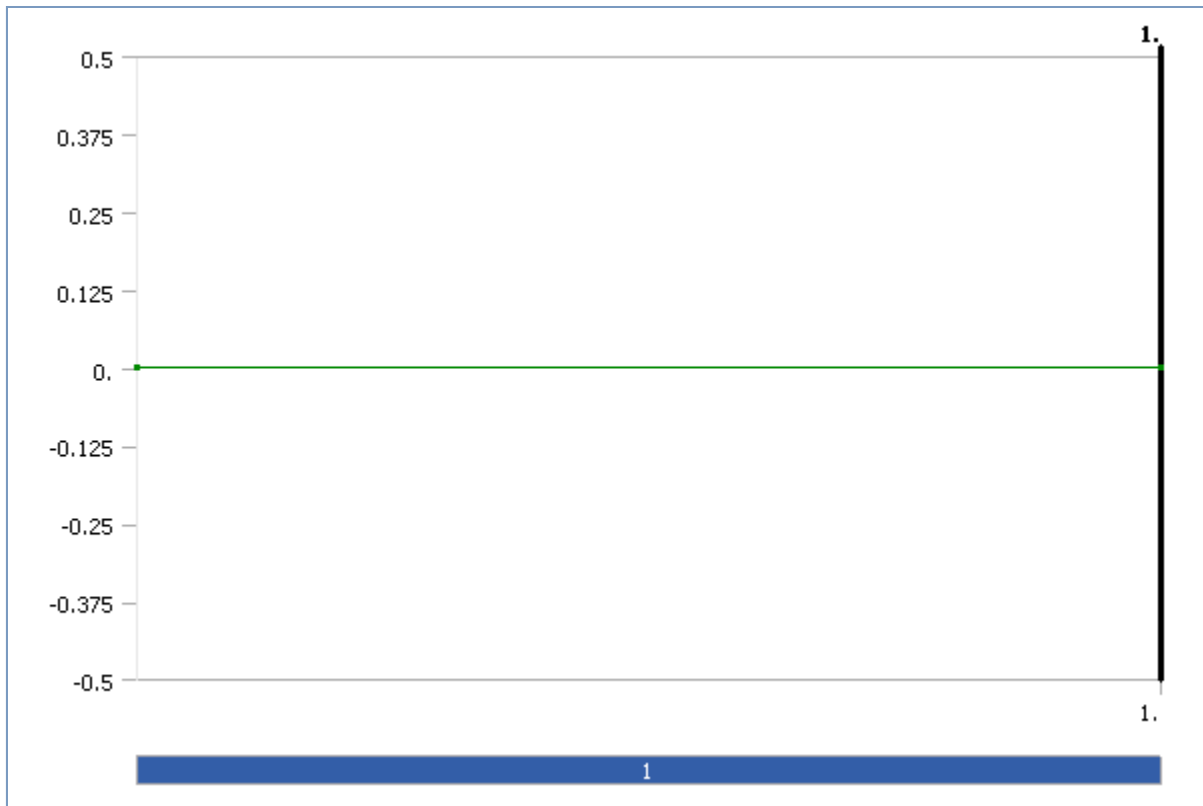

FIGURE 4
Model > Static Structural > Right Upstream

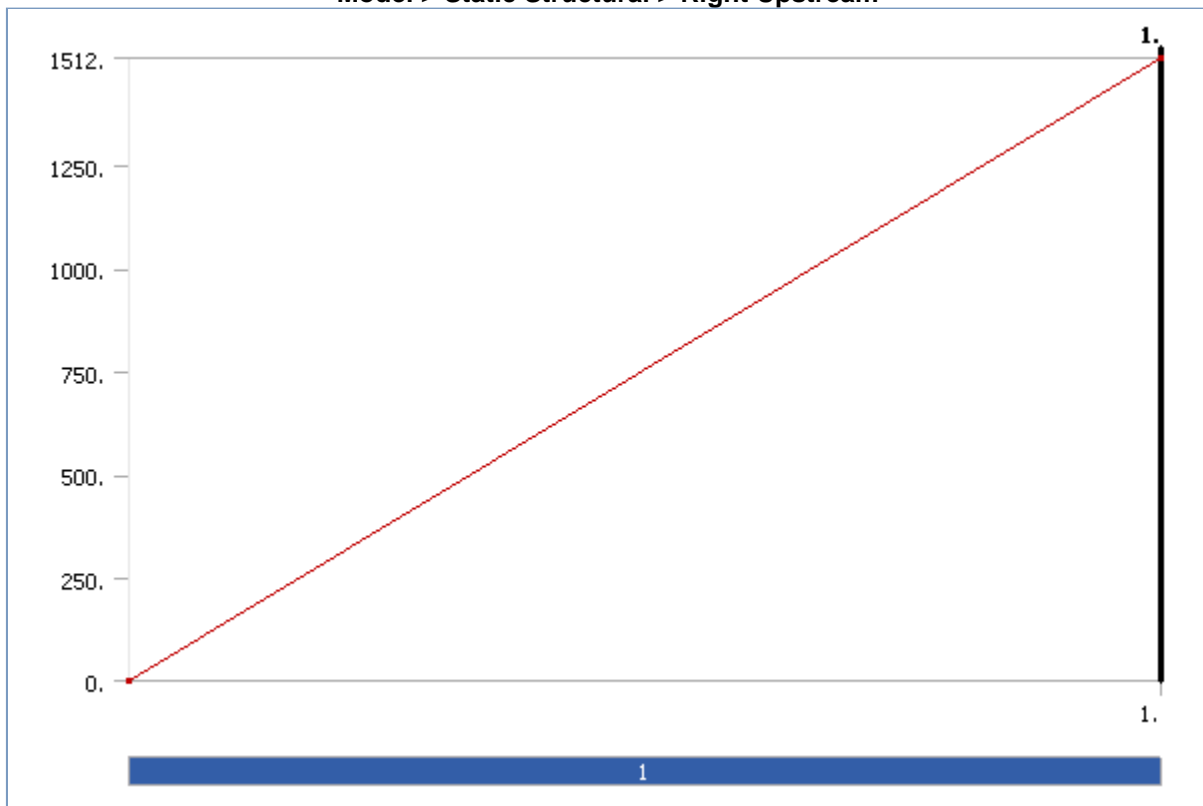

FIGURE 5
Model > Static Structural > Right Downstream

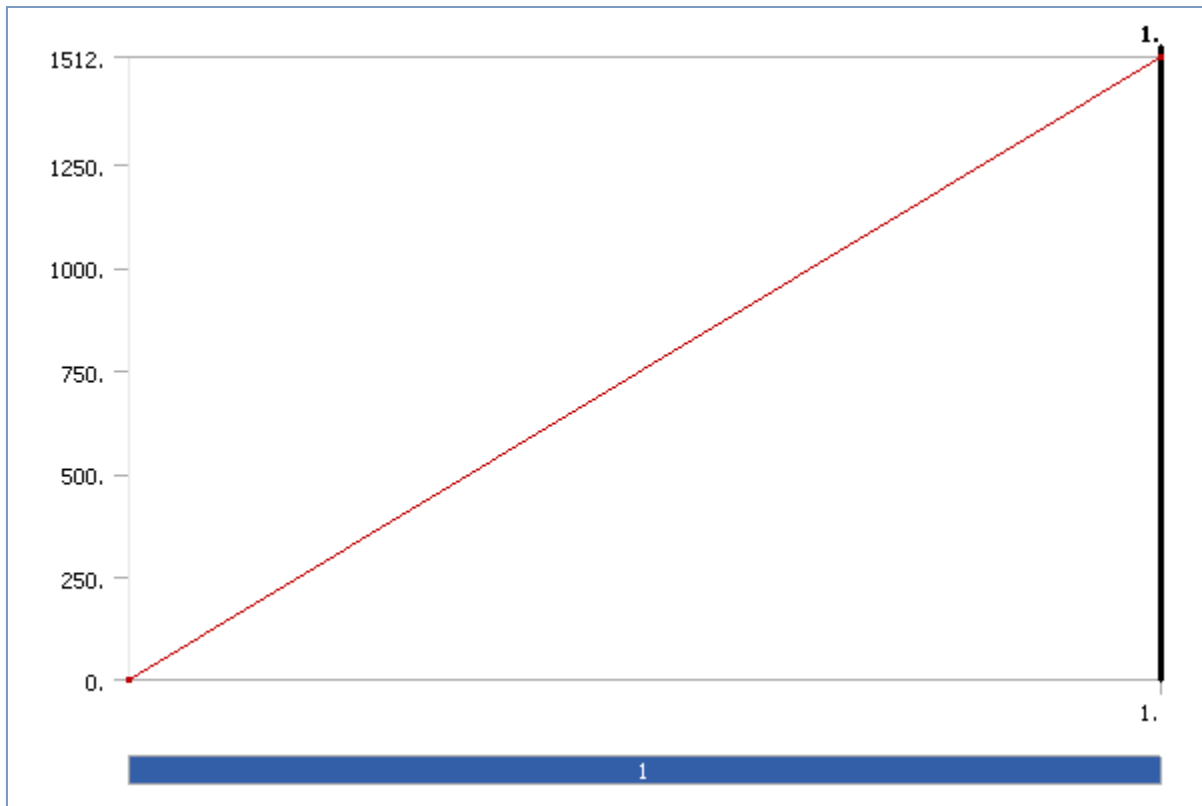

TABLE 27
Model > Static Structural > Loads

Object Name	<i>Left Upstream</i>	<i>Left Downstream</i>
State	Fully Defined	
Scope		
Scoping Method	Geometry Selection	
Geometry	1 Face	
Definition		
Define By	Vector	
Type	Force	
Magnitude	1512. N (ramped)	
Direction	Defined	
Suppressed	No	

FIGURE 6
Model > Static Structural > Left Upstream

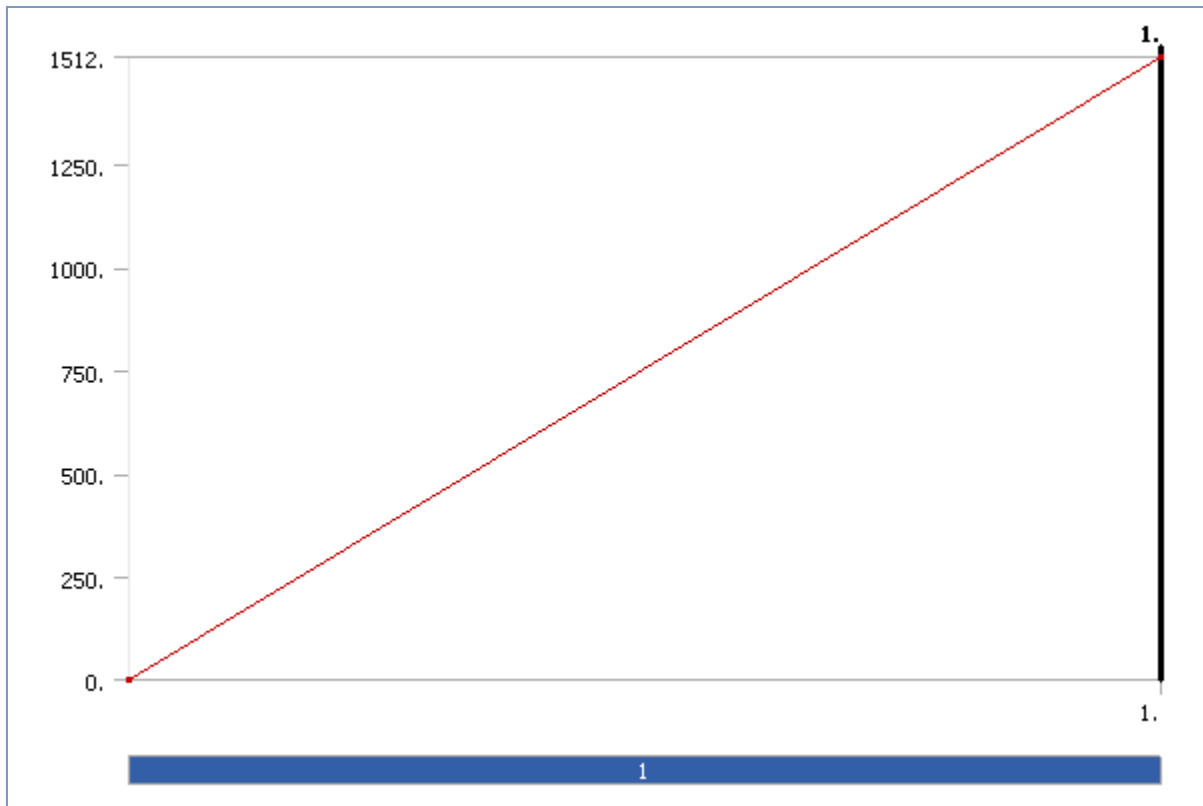
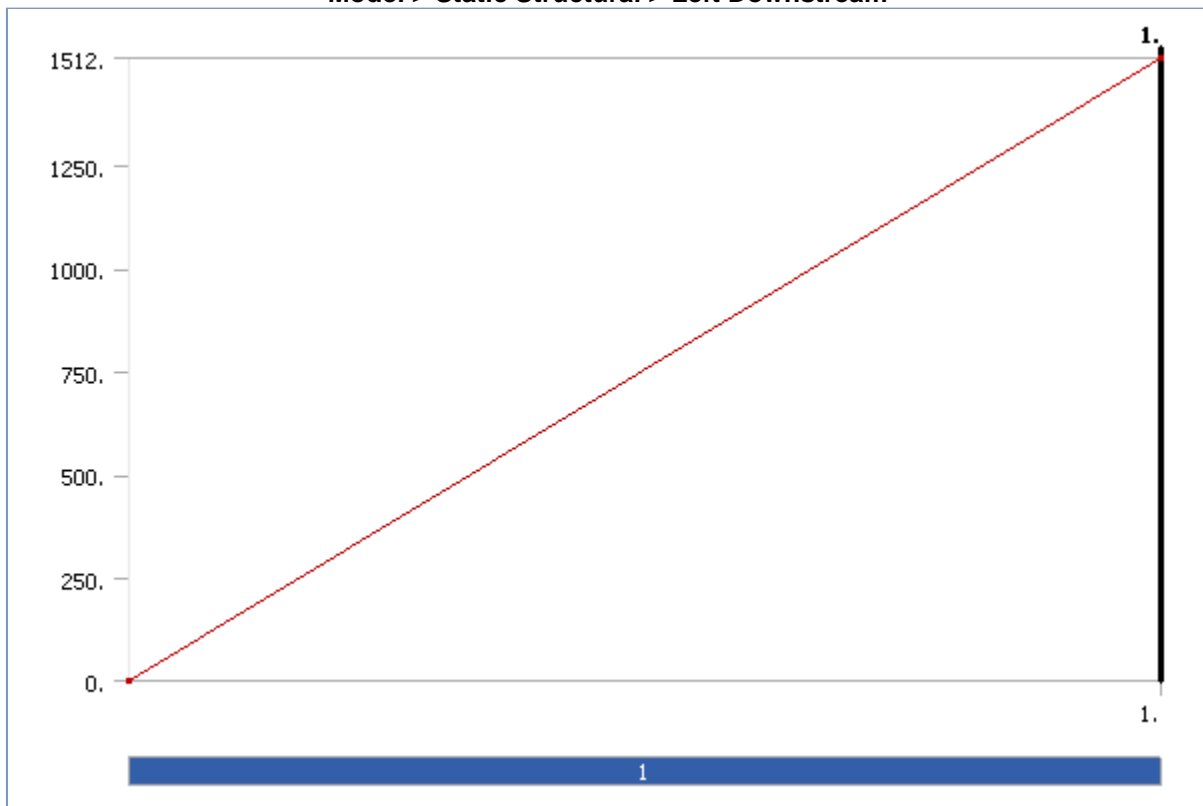

FIGURE 7
Model > Static Structural > Left Downstream



Solution

TABLE 28
Model > Static Structural > Solution

Object Name	<i>Solution</i>
State	Solved
Adaptive Mesh Refinement	
Max Refinement Loops	1.
Refinement Depth	2.

TABLE 29
Model > Static Structural > Solution > Solution Information

Object Name	<i>Solution Information</i>
State	Solved
Solution Information	
Solution Output	Solver Output
Newton-Raphson Residuals	0
Update Interval	2.5 s
Display Points	All

TABLE 30
Model > Static Structural > Solution > Results

Object Name	<i>Total Deformation</i>	<i>X Deformation</i>	<i>Y Deformation</i>	<i>Z Deformation</i>	<i>Equivalent Stress</i>
State	Solved				
Scope					
Geometry	All Bodies				
Definition					
Type	Total Deformation	Directional Deformation			Equivalent (von-Mises) Stress
Display Time	End Time				
Orientation		X Axis	Y Axis	Z Axis	
Shell					Top/Bottom
Results					
Minimum	0. mm	-0.73364 mm	-0.26129 mm	-4.9934e-002 mm	6.9989e-029 MPa
Maximum	0.84694 mm	0.62668 mm	0.44016 mm	0.74875 mm	12.055 MPa
Minimum Occurs On	Nose Plate	Right Endplate Inner Steel Slice	Rod 4	Right Endplate Aluminum Casing	60 Deg Ref line
Maximum Occurs On	Right Endplate Outer Steel slice	Left Endplate Inner Steel slice	Right Endplate Outer Steel slice	Rod 4	Rod 1
Information					
Time	1. s				
Load Step	1				
Substep	1				
Iteration Number	1				

FIGURE 8
Model > Static Structural > Solution > Total Deformation > Figure

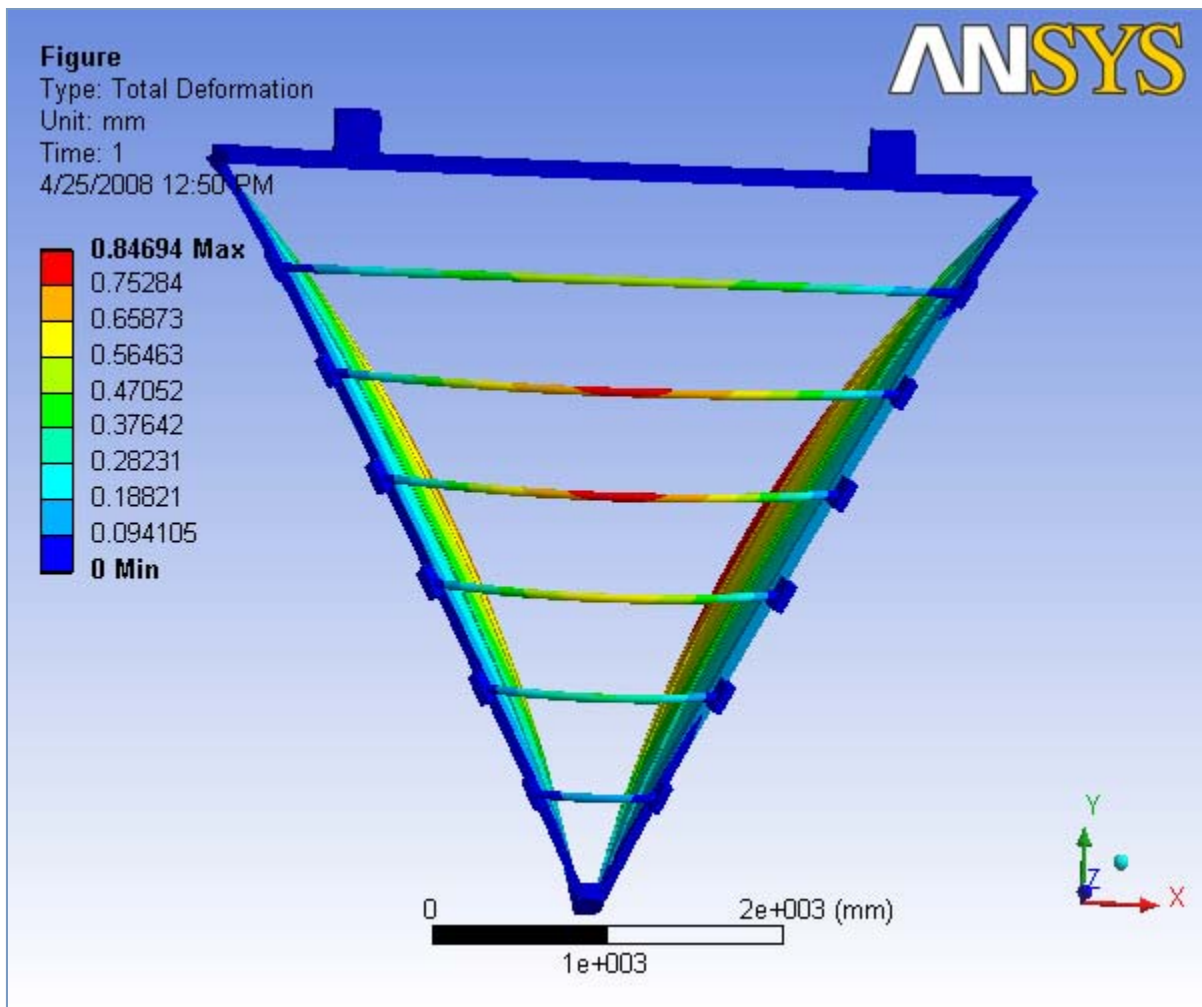

FIGURE 9
Model > Static Structural > Solution > X Deformation > Figure

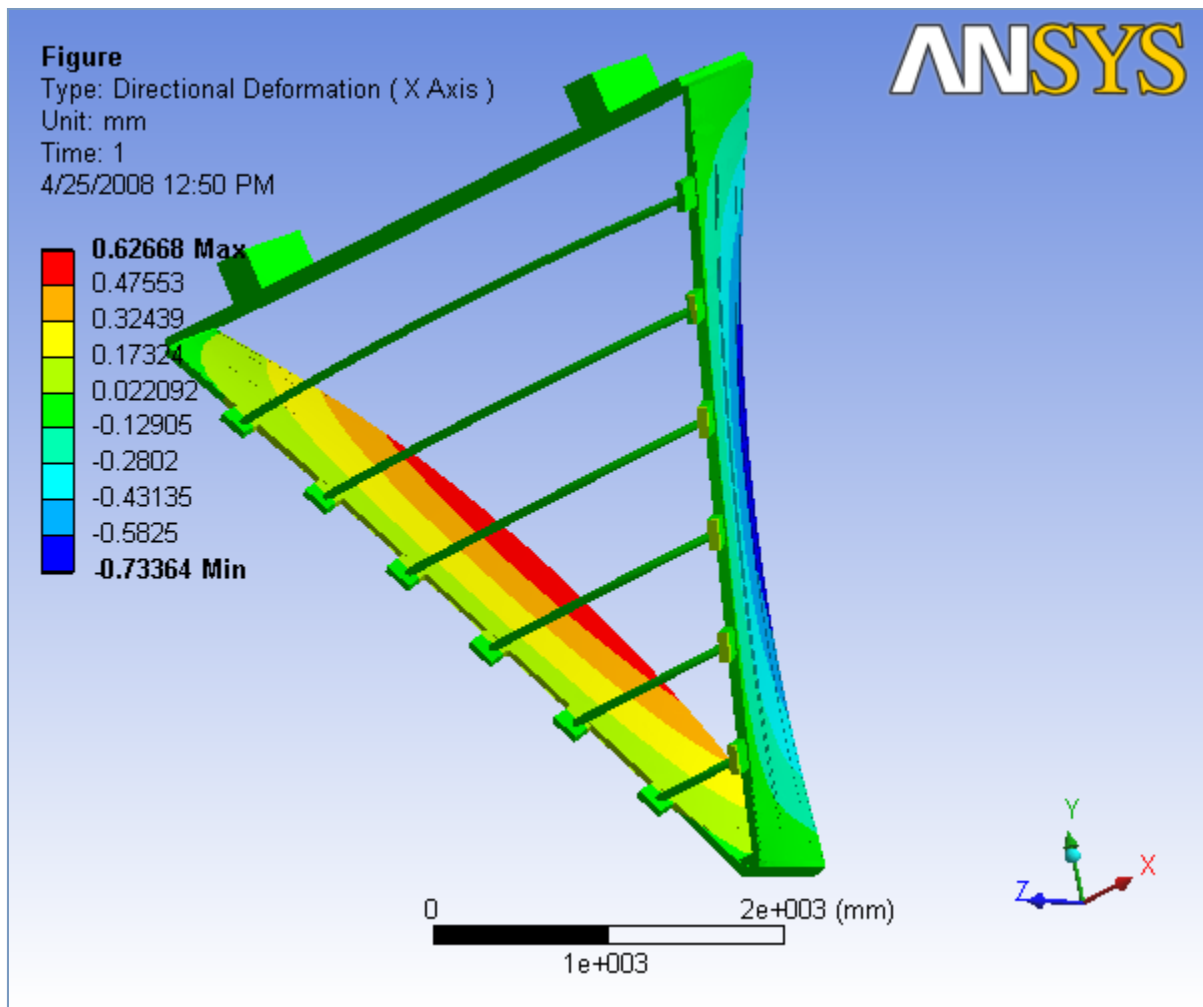

FIGURE 10
Model > Static Structural > Solution > Y Deformation > Figure

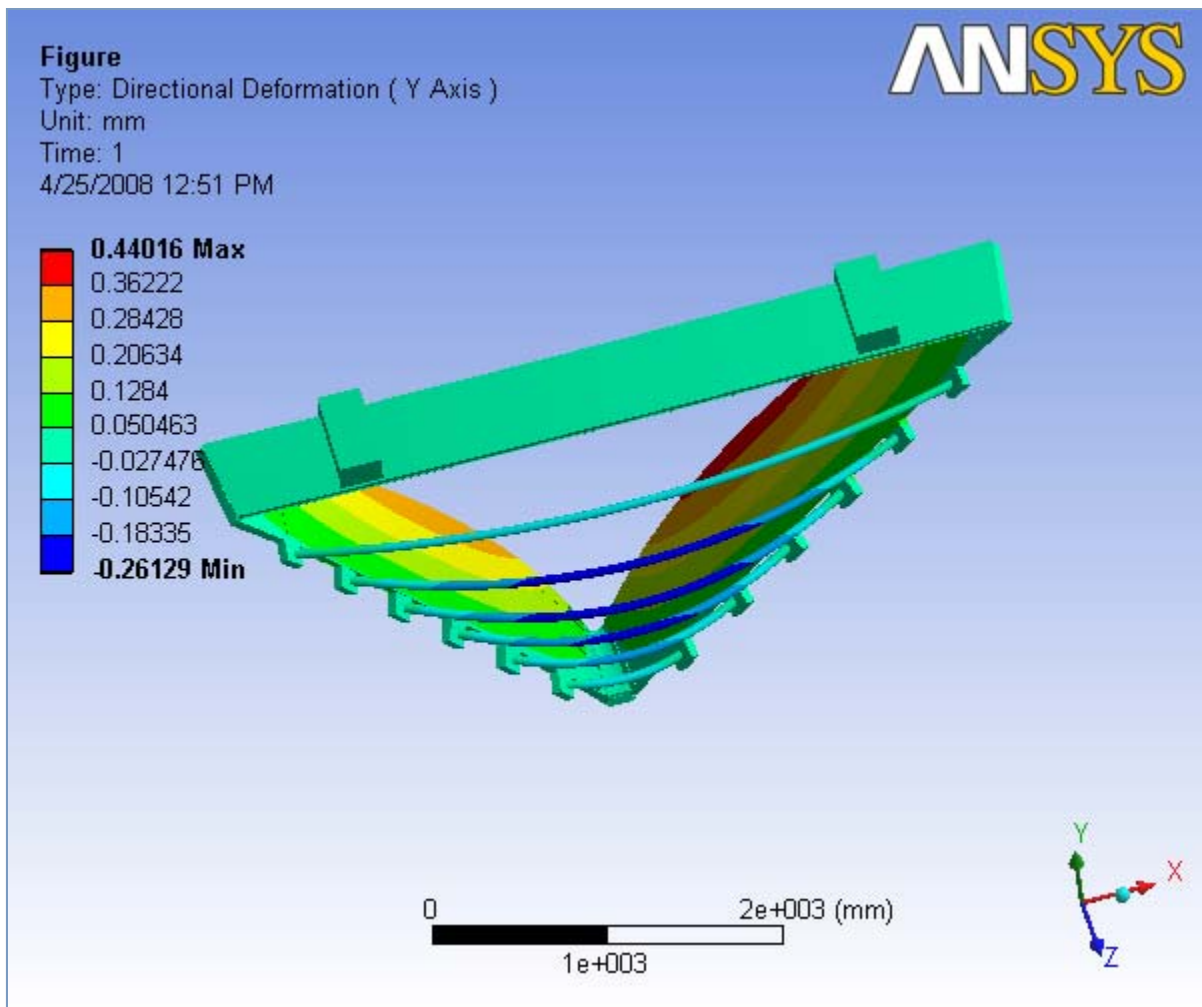

FIGURE 11
Model > Static Structural > Solution > Z Deformation > Figure

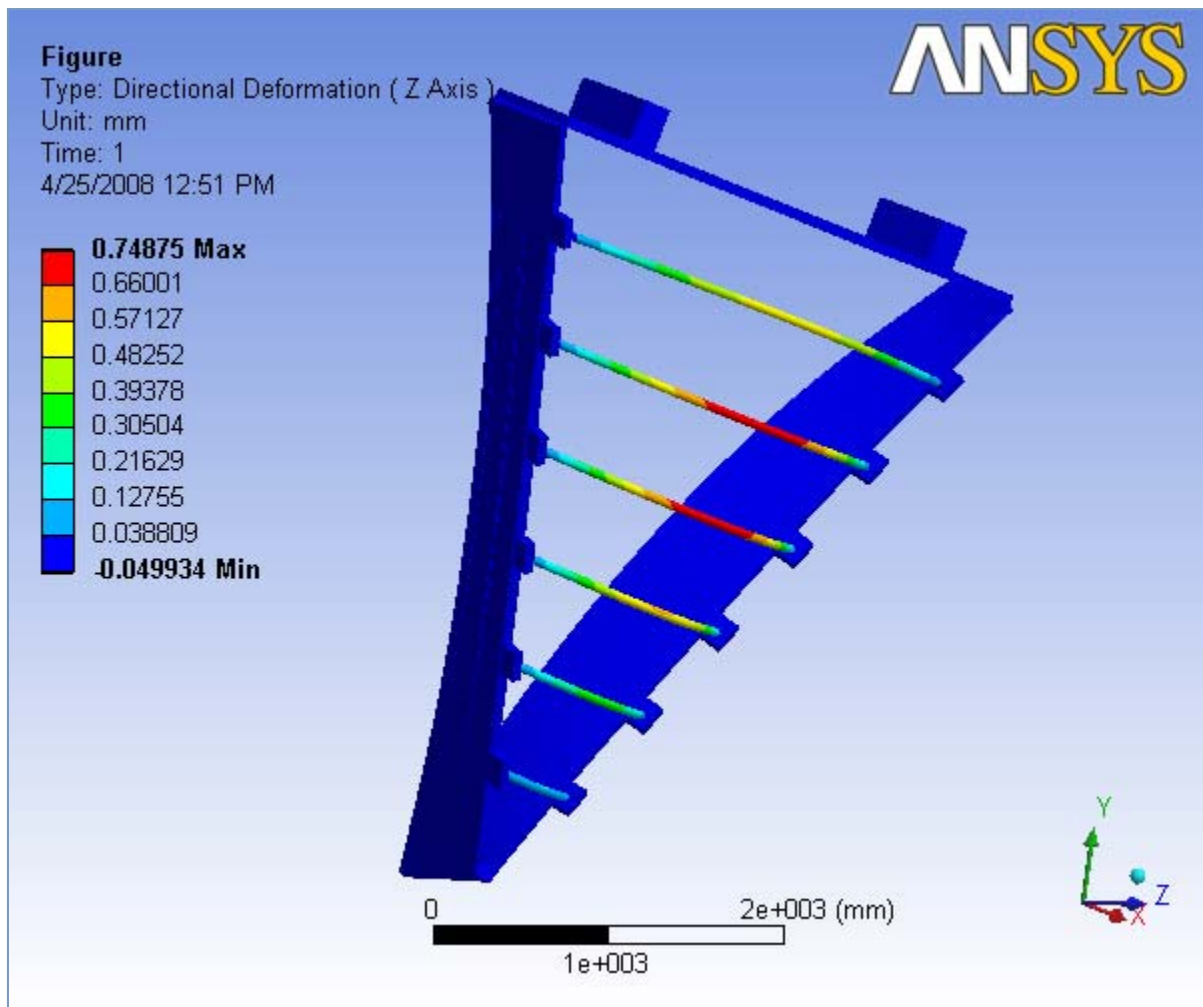

FIGURE 12
Model > Static Structural > Solution > Equivalent Stress > Figure

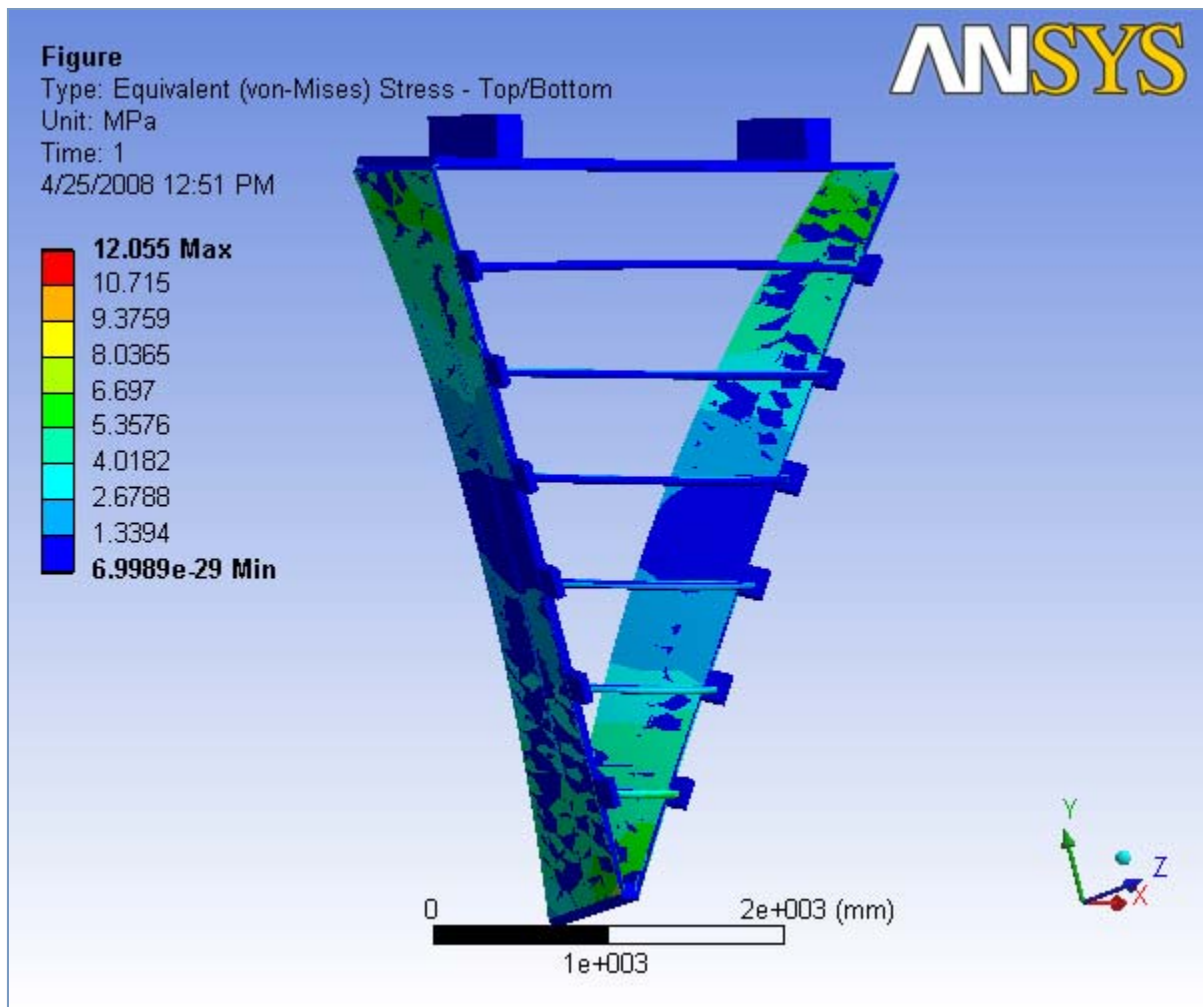
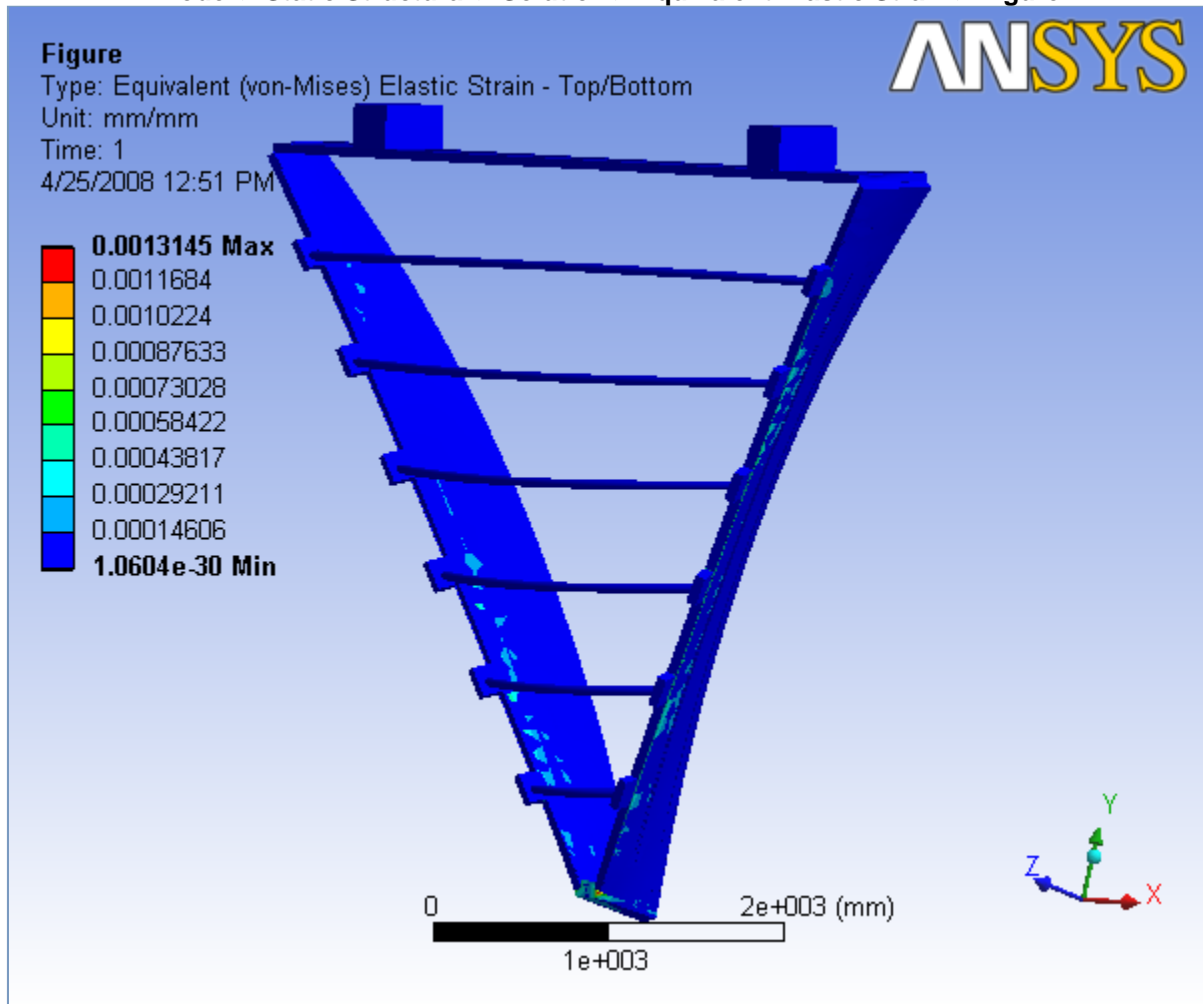

TABLE 31
Model > Static Structural > Solution > Results

Object Name	<i>Equivalent Elastic Strain</i>
State	Solved
Scope	
Geometry	All Bodies
Definition	
Type	Equivalent (von-Mises) Elastic Strain
Shell	Top/Bottom
Display Time	End Time
Results	
Minimum	1.0604e-030 mm/mm
Maximum	1.3145e-003 mm/mm
Minimum Occurs On	60 Deg Ref line
Maximum Occurs On	Nose Plate
Information	
Time	1. s
Load Step	1
Substep	1
Iteration Number	1

FIGURE 13

Model > Static Structural > Solution > Equivalent Elastic Strain > Figure



Material Data

Polyurethane

TABLE 32
Polyurethane > Constants

Structural	
Young's Modulus	66. MPa
Poisson's Ratio	0.
Density	2.4e-007 kg/mm ³
Thermal Expansion	6.12e-005 1/°C
Thermal	
Thermal Conductivity	0. W/mm·°C
Specific Heat	0. J/kg·°C
Electromagnetics	
Relative Permeability	0.
Resistivity	0. Ohm-mm

Aluminum

TABLE 33
Aluminum > Constants

Structural	
Young's Modulus	68900 MPa
Poisson's Ratio	0.33
Density	2.7e-006 kg/mm ³
Thermal Expansion	2.3e-005 1/°C
Thermal	
Thermal Conductivity	0. W/mm·°C
Specific Heat	0. J/kg·°C
Electromagnetics	
Relative Permeability	0.
Resistivity	0. Ohm·mm

Stainless Steel

TABLE 34
Stainless Steel > Constants

Structural	
Young's Modulus	1.93e+005 MPa
Poisson's Ratio	0.3
Density	8.e-006 kg/mm ³
Thermal Expansion	0. 1/°C
Thermal	
Thermal Conductivity	1.63e-002 W/mm·°C
Specific Heat	500. J/kg·°C
Electromagnetics	
Relative Permeability	0.
Resistivity	0. Ohm·mm

Carbon fiber

TABLE 35
Carbon fiber > Constants

Structural	
Young's Modulus	1.5e+005 MPa
Poisson's Ratio	0.
Density	5.8e-007 kg/mm ³
Thermal Expansion	0. 1/°C
Thermal	
Thermal Conductivity	0. W/mm·°C
Specific Heat	0. J/kg·°C
Electromagnetics	
Relative Permeability	0.
Resistivity	0. Ohm·mm