

8 7 6 5 4 3 2 1

REVISIONS				
ZONE	REV.	DESCRIPTION	DATE	APPROVED

D
C
B
A

D
C
B
A

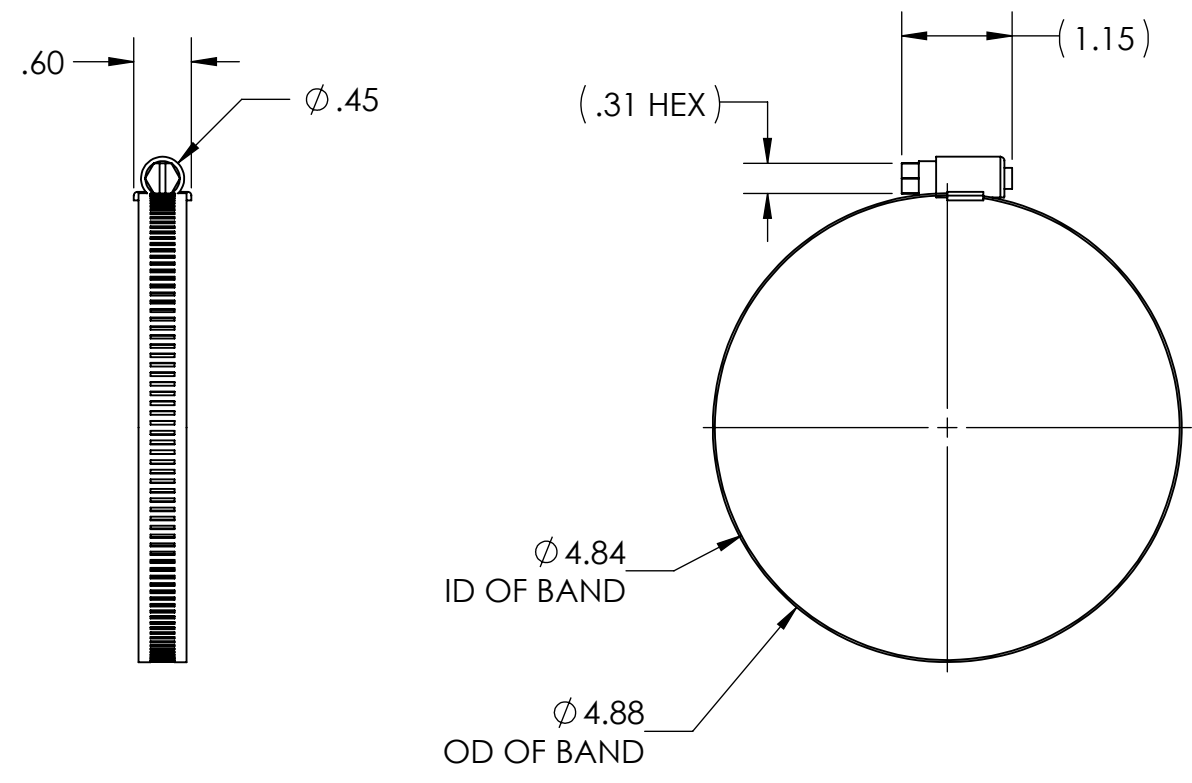
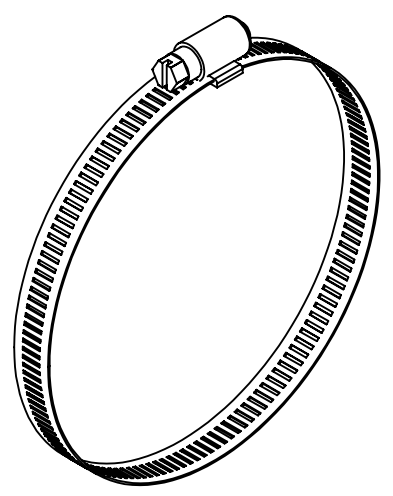

PROPRIETARY AND CONFIDENTIAL
 THE INFORMATION CONTAINED IN THIS DRAWING IS THE SOLE PROPERTY OF EMPIRE MAGNETICS, INC. ANY REPRODUCTION IN PART OR AS A WHOLE WITHOUT THE WRITTEN PERMISSION OF EMPIRE MAGNETICS, INC. IS PROHIBITED.

		UNLESS OTHERWISE SPECIFIED:		NAME	DATE	EMPIRE MAGNETICS, INC. ROHNERT PARK, CA 94928	
		DIMENSIONS ARE IN INCHES		DRAWN	DTI	8-30-11	
		TOLERANCES:		CHECKED		TITLE:	
		FRACTIONAL \pm		ENG APPR.		HOSE CLAMP	
		ANGULAR: ± 0.5		MFG APPR.			
		TWO PLACE DECIMAL $\pm .010$		Q.A.			
		THREE PLACE DECIMAL $\pm .005$		COMMENTS:			
		INTERPRET GEOMETRIC TOLERANCING PER:					
		MATERIAL					
		ANY STAINLESS STEEL					
NEXT ASSY	USED ON	FINISH					
		N/A					
APPLICATION		DO NOT SCALE DRAWING					
				SIZE	DWG. NO.	REV	
				B	HOSE CLAMP		
				SCALE: 1:2		SHEET 1 OF 1	

8 7 6 5 4 3 2 1