



POWER SUPPLIES - NARROW PROFILE, Wide Adjust Output

INSTALLATION AND OPERATION

Threaded holes on the bottom and one side surface may be used for mounting, or the supply may be rear mounted using the same holes that attach the rear cover plate. An accessory Mounting Kit (model NP6) is available to enable mounting the power supply when the opposite side of the mounting surface is inaccessible.

Even a relatively small amount of air flowing around and through a power supply will significantly reduce the rise in its temperature resulting from operation, and therefore the temperature of the critical components within it, improving both reliability and stability. Avoid blocking air flow through vented surfaces. If the perforated bottom of a supply is mounted to a solid surface, use spacers at least 3/16" thick between it and the surface to which it is fastened, to permit convection air flow, or punch ventilation holes in the mounting surface. Allow free air to circulate around heat sinks. Space at least one inch away from surrounding objects.

Make all connections before applying AC input power.

THE SENSING TERMINALS MUST BE CONNECTED to the output terminals, either at the barrier strip on the power supply or at the load. Failure to have the sense terminals connected will affect the output voltage (usually causing it to be higher than the rating of the supply, and unadjustable), and may result in permanent damage to both the power supply and its load. If voltage drops in the output voltage leads (which degrade regulation) are not objectionable, local sensing can be used; leave in place the jumpers provided with the power supply on the barrier strip (connecting the +SENS to the +OUT terminal and the -SENS to the -OUT terminal). However, if the best possible regulation at the load is required, then remove the jumpers and use two additional leads to connect the sense terminals to the output leads at the load, as shown in the schematic. This configuration permits the power supply to sense and compensate the voltage actually across the load. Note that remote sensing is capable of compensating only limited wiring drops. The voltage across the load, plus the voltage drops through the wiring, must be within the output voltage range of the supply for the voltage at the load to remain within the load regulation specification.

If there is any possibility of voltage from another source (another power supply, a battery, transients, etc) being applied to the power supply's output terminals, protect the power supply by using a diode in series with one of the output leads.

Do not attempt to directly parallel the outputs of two power supplies. This would result in current flowing from the higher-set output into the lower-set output, and probable damage to both circuits. Outputs may be connected in series to obtain a higher voltage provided that a reverse-biased diode, having PIV and current ratings exceeding the combined output, is used across each output; however, keep in mind that the output current to be drawn cannot exceed the output current rating of the lowest rated supply used.

Frequent fuse failure is symptomatic of power supply overload, a short circuited output, a tripped overvoltage protector, or power supply failure. Do not overfuse; this can result in damage to the power supply.

If the AC input power contains large voltage spikes ('noise') induced by the switching of high currents, inductive loads, electro-mechanical components, etc., the input power leads to the supply should include some means of transient suppression. Otherwise, a portion of the noise may be coupled through the supply to the load. Also, the supply could be damaged. The means of suppression that is easiest to install is a 1 mfd capacitor or a metal oxide surge suppressor (MOV) across the AC input terminals of the supply. In extremely severe cases, the use of RF chokes in series with each side of the line may also be required.

Current limiting and short circuit protection: all models have a rolloff characteristic with automatic recovery.

The overvoltage protection circuit of power supplies equipped with this option will trip whenever the output voltage rises to the trip voltage (even if only instantaneously, as can occur if a load transient feeds back into the power supply), and will remain latched until the output voltage is interrupted. It can be reset without changing the control settings simply by switching the power supply off momentarily.

**ALL ACOPIAN
POWER SUPPLIES
MADE IN U.S.A.**

WARRANTY: Acopian power supplies are warranted to be free from defects in material and workmanship for a period of five years (encapsulated devices and fans, for one year) from date of original shipment. Acopian's obligation under this warranty is limited to repairing any power supply returned to the factory Service Department in Easton, PA and replacing any defective parts. Authorization must be obtained from Acopian before a power supply may be returned for repair. Transportation charges are to be paid by the purchaser. A reinspection and handling charge will be applied to returned units found to have no defects. If a failure has been caused by misuse, operation in excess of specifications, or modification by the customer, repairs will be billed at cost; in such cases, a cost estimate will be submitted before work is started.

Acopian reserves the right to make changes or improvements in its products without incurring any obligation to install the same on products previously manufactured.

This warranty is in lieu of all other warranties, obligations, and liabilities, expressed or implied, and is the purchaser's exclusive remedy. Acopian makes no warranty, either express or implied, of merchantability, fitness for a particular purpose or otherwise. In no event shall Acopian be liable for incidental or consequential damages of any kind, including loss of business or profits, or any other losses incurred by the purchaser or any third party.

The validity, performance and construction of all terms and conditions and any sale made by Acopian shall be determined by the law of Pennsylvania, not including its law of conflict of laws.

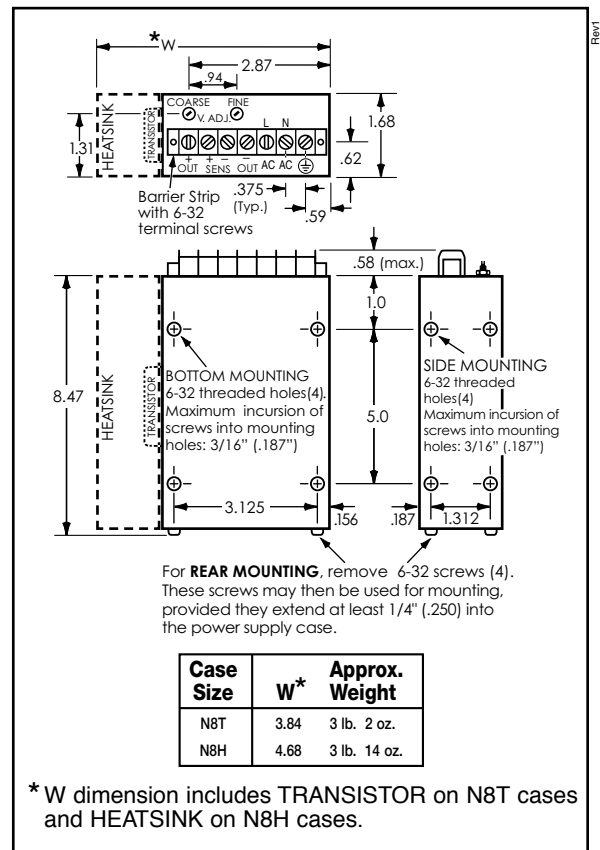

Case Size	W*	Approx. Weight
N8T	3.84	3 lb. 2 oz.
N8H	4.68	3 lb. 14 oz.

* W dimension includes TRANSISTOR on N8T cases and HEATSINK on N8H cases.



The complete Acopian catalog is available on the Internet at <http://www.acopian.com>
P.O. Box 638, Easton, PA 18044 • Phone: (610) 258-5441 • FAX: (610) 258-2842



POWER SUPPLIES - NARROW PROFILE, Wide Adjust Output

Acopian modular power supplies are ideally suited to all applications where compact, high performance and high reliability power supplies are required. Modular construction and barrier strip interconnections provide mounting and wiring convenience and flexibility. All models have floating outputs which may be used floating, with either the positive or negative side grounded, and/or in series with another supply(ies). All have built-in short circuit protection and provision for remote sensing of output voltage at the load for applications where voltage regulation is critical. They are conservatively rated for operation at ambient temperatures to +71°C.

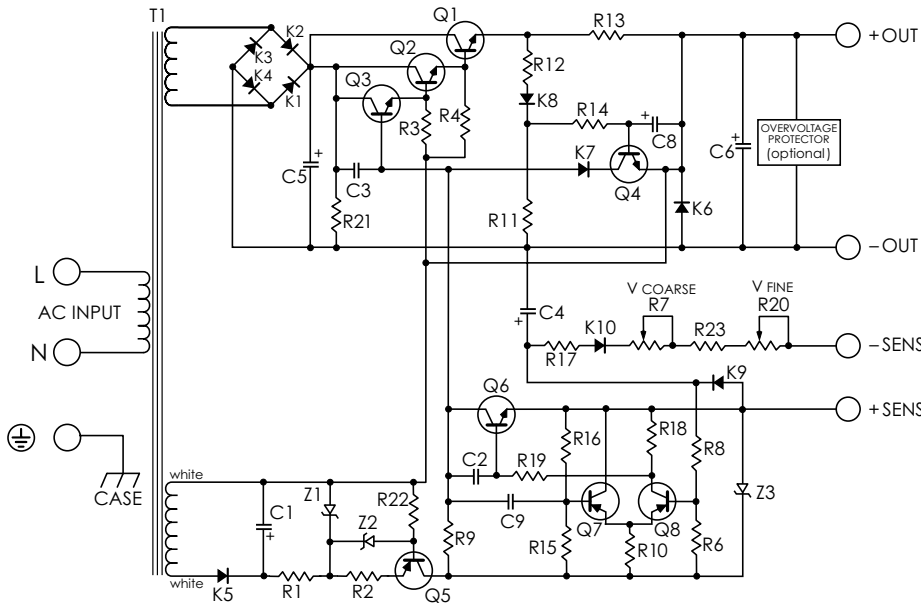

105 -125 VAC, 50-400Hz
(Standard)

210-250 VAC, 50-400Hz
(When model number ends in -230)

The MODEL NUMBER indicates any included options;
 prefix V: overvoltage protection
 suffix F: fungus proofing
 suffix M: terminal strip cover
 suffix -230: 230v input

Connecting Power Supply to the LOAD:

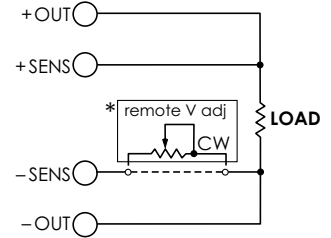

* THE DOTTED LINE CONNECTION IS REQUIRED, unless remote voltage adjustment is used. A potentiometer OR switched resistors in the negative sense lead may be used to remotely program (adjust) the output voltage:

If using a potentiometer (as shown above), the built-in adjustments must be turned fully CCW.

The remote potentiometer(s) should have these values:

For 0-7v, 0-18v, 0-32v models:

use a 5K pot (0.5w) for V COARSE adj,
 use a 500 ohm pot (0.5w) for V FINE adj.

For 0-60v, 0-150v models:

use a 50K pot (0.5w) for V COARSE adj,
 use a 2.5K pot (0.5w) for V FINE adj.

If using switched resistors, the built-in output voltage controls must be turned counterclockwise at least to a point where the minimum desired resistance can be obtained with the minimum external resistance used. The switch should be of the make-before-break type; damage to the power supply, and to the load, may result from the output voltage surges caused by open-circuiting the sensing circuit while the supply is in operation. Use these values:

P.S. Output Voltage Range	Ohms/Volt
0 to 7v	700
0 to 18v	270
0 to 32v	150
0 to 60v	820
0 to 150v	330

CAUTION: To provide protection from risk of fire, include in the AC input wiring a 250V time-delay fuse with the amp rating listed below:
 (These fuse ratings are for 115V input models only; contact factory for fuse ratings for 230V input models.)

MODEL Fuse size

A07XN100	3/10
A07NX210	6/10
A018XN40	1/4
A018NX100	1/2
A032XN25	3/10
A032NX60	1/2
A060NX12	1/4
A060NX25	3/8
A0150NX05	1/4
A0150NX10	3/8

